



Rc-NPT-NPTF



Rc NPT NPTF

Forte espansione sui mercati esteri
Great expansion in export markets

INTERNATIONAL



MASCHI A MACCHINA MACHINE TAPS

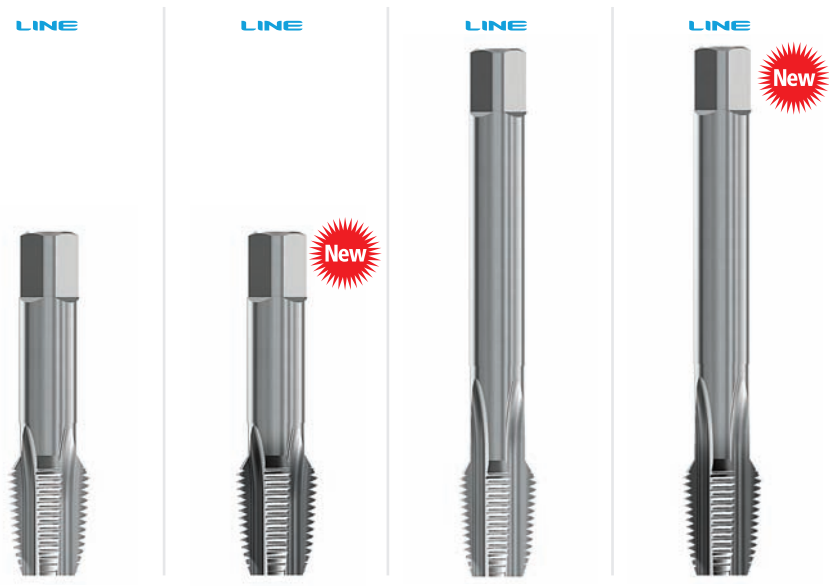
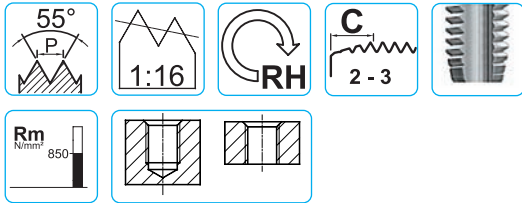
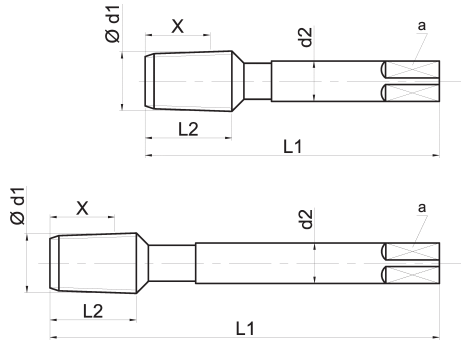

Profondità di filettatura - Thread depth	-	-	-	-
Materiale - Material	HSSE	HSSE	HSSE	HSSE
Tolleranza - Tolerance	-	-	-	-
Trattamento superficiale - Surface treatment	BR	VS	BR	VS
Numero gruppi materiali Material's groups number	1.1 1.2 1.3 1.4	1.1 1.2 1.3 1.4	1.1 1.2 1.3 1.4	1.1 1.2 1.3 1.4
	3.3 3.4 4.2 4.3	2.1 2.2 2.3	3.3 3.4 4.2 4.3	2.1 2.2 2.3
	5.3	3.1 3.2 3.3 3.4	5.3	3.1 3.2 3.3 3.4
		4.2 4.3 4.4 5.2 5.3		4.2 4.3 4.4 5.2 5.3

Ød1 Rc	P TPI	Ø mm	L ₁	L ₂	d ₂ h9	a h12	X	F*
1/8	28	9,728	63	13	7	5,5	10,1	8,20
1/4	19	13,157	63	20	11	9	15,0	11
3/8	19	16,662	70	20	12	9	15,4	14,5
1/2	14	20,955	80	26	16	12	20,4	18
3/4	14	26,441	100	28	20	16	21,7	23,5
1"	11	33,249	110	34	25	20	26	29,5
1 1/4"	11	41,910	125	36	32	24	28,3	38
1 1/2"	11	47,803	140	36	36	29	28,3	44
2"	11	59,614	160	40	45	35	32,6	55,5

CODICE - CODE	
E21CRC...	E21CRC...VS
○	*
○	*
○	*
○	*
○	*
○	*
○	*
○	*

Ød1 Rc	P TPI	Ø mm	L ₁	L ₂	d ₂ h9	a h12	X	F*
1/8	28	9,728	90	13	7	5,5	10,1	8,20
1/4	19	13,157	100	20	11	9	15,0	11
3/8	19	16,662	110	20	12	9	15,4	14,5
1/2	14	20,955	125	26	16	12	20,4	18
3/4	14	26,441	140	28	20	16	21,7	23,5
1"	11	33,249	160	34	25	20	26	29,5
1 1/4"	11	41,910	160	36	32	24	28,3	38
1 1/2"	11	47,803	190	36	36	29	28,3	44
2"	11	59,614	200	40	45	35	32,6	55,5

CODICE - CODE	
E21LRC...	E21LRC...VS
○	*
○	*
○	*
○	*
○	*
○	*
○	*
○	*
○	*

Per accoppiamento a tenuta sul filetto.
Where pressure-tight joints are made on the threads.
Für im Gewinde dichtende Verbindungen.
Pour assemblage avec étanchéité dans le filet.
Para conexiones herméticas en la rosca.

* Diametri di foratura cilindrici.
Per alesatura conica vedi tabella pag. 258
* Cilyndric hole.
For conic hole see on page 258

Confezione: Singola Box: Single	€ Pagina listino - Price list page	97	97	98	98
	● Standard	○ Disponibilità da richiedere, prezzo a listino	○ Lead time on enquiry, standard price-list	* Solo a richiesta	* Only on request

MASCHI A MACCHINA MACHINE TAPS

N **USO GENERALE**
General purpose

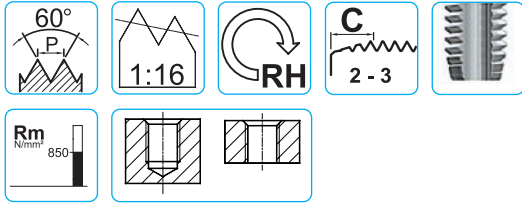
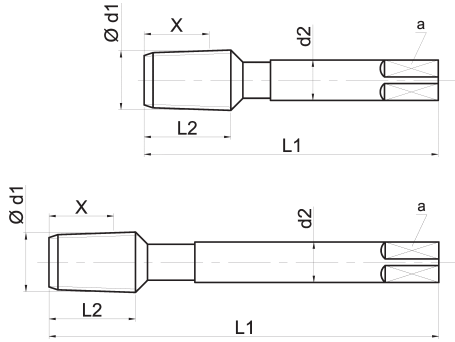

Profondità di filettatura - Thread depth	-
Materiale - Material	HSSE
Tolleranza - Tolerance	-
Trattamento superficiale - Surface treatment	BR
Numero gruppi materiali Material's groups number	1.1 1.2 1.3 1.4
	3.3 3.4 4.2 4.3
	5.3
	4.2 4.3 4.4 5.2 5.3

-	-	-	-
HSSE	HSSE	HSSE	HSSE
-	-	-	-
BR	VS	BR	VS
1.1 1.2 1.3 1.4	1.1 1.2 1.3 1.4	1.1 1.2 1.3 1.4	1.1 1.2 1.3 1.4
3.3 3.4 4.2 4.3	2.1 2.2 2.3	3.3 3.4 4.2 4.3	2.1 2.2 2.3
5.3	3.1 3.2 3.3 3.4	5.3	3.1 3.2 3.3 3.4
	4.2 4.3 4.4 5.2 5.3		4.2 4.3 4.4 5.2 5.3

Ød1 NPT	P TPI	Ø mm	L ₁	L ₂	d ₂ h9	a h12	X	F*
1/16	27	7,938	63	13	6	4,9	9,3	6,2
1/8	27	10,287	63	13	7	5,5	9,3	8,5
1/4	18	13,716	63	20	11	9	13,5	11
3/8	18	17,145	70	20	12	9	13,9	14,5
1/2	14	21,336	80	26	16	12	18,1	17,9
3/4	14	26,670	100	26	20	16	18,6	23,2
1"	11,5	33,401	110	32	25	20	22,3	29
1 1/4"	11,5	42,164	125	32	32	24	22,8	37,8
1 1/2"	11,5	48,260	140	32	36	29	22,8	44
2"	11,5	60,325	160	36	45	35	23,2	56

CODICE - CODE	
E21CNPT...	E21CNPT...VS
*	*
o	*
o	*
o	*
o	*
o	*
o	*
o	*
o	*
o	*

Ød1 NPT	P TPI	Ø mm	L ₁	L ₂	d ₂ h9	a h12	X	F*
1/16	27	7,938	90	13	6	4,9	9,3	6,2
1/8	27	10,287	90	13	7	5,5	9,3	8,5
1/4	18	13,716	100	20	11	9	13,5	11
3/8	18	17,145	110	20	12	9	13,9	14,5
1/2	14	21,336	125	26	16	12	18,1	17,9
3/4	14	26,670	140	26	20	16	18,6	23,2
1"	11,5	33,401	160	32	25	20	22,3	29
1 1/4"	11,5	42,164	160	32	32	24	22,8	37,8
1 1/2"	11,5	48,260	190	32	36	29	22,8	44
2"	11,5	60,325	200	36	45	35	23,2	56

CODICE - CODE	
E21LNPT...	E21LNPT...VS
o	*
o	*
o	*
o	*
o	*
o	*
*	*
*	*
*	*

■ = Acciaio HSS / HSS Steel

* Diametri di foratura cilindrici.
Per alesatura conica vedi tabella pag. 258

* Cylindric hole.
For conic hole see on page 258



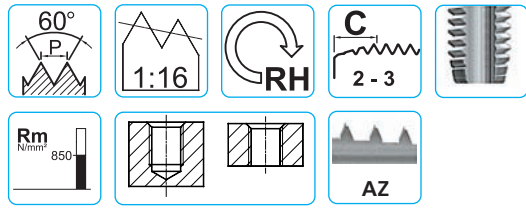
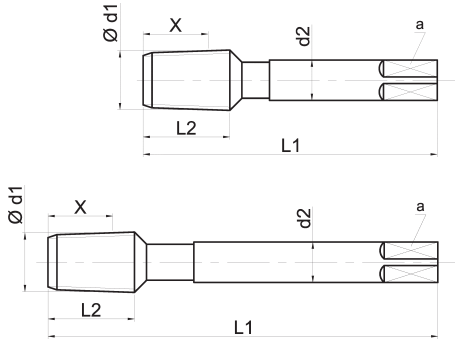

Confezione: Singola Box: Single	€ Pagina listino - Price list page	98	98	98	98
	● Standard	○ Disponibilità da richiedere, prezzo a listino		★ Solo a richiesta	
	● Standard	○ Lead time on enquiry, standard price-list		★ Only on request	

N **USO GENERALE**
General purpose

MASCHI A MACCHINA MACHINE TAPS



Profondità di filettatura - Thread depth
 Materiale - Material
 Tolleranza - Tolerance
 Trattamento superficiale - Surface treatment
 Numero gruppi materiali
 Material's groups number

			
-	-	-	-
HSSE	HSSE	HSSE	HSSE
-	-	-	-
BR	VS	BR	VS
1.1	1.1	1.1	1.1
2.1 2.2	2.1 2.2	2.1 2.2	2.1 2.2
4.1 4.2 5.1 5.2	4.1 4.2 5.1 5.2	4.1 4.2 5.1 5.2	4.1 4.2 5.1 5.2

Ød1 NPT	P TPI	Ø mm	L ₁	L ₂	d ₂ h9	a h12	X	F*
1/16	27	7,938	63	13	6	4,9	9,3	6,2
1/8	27	10,287	63	13	7	5,5	9,3	8,5
1/4	18	13,716	63	20	11	9	13,5	11
3/8	18	17,145	70	20	12	9	13,9	14,5
1/2	14	21,336	80	26	16	12	18,1	17,9
3/4	14	26,670	100	26	20	16	18,6	23,2
1"	11,5	33,401	110	32	25	20	22,3	29
1 1/4"	11,5	42,164	125	32	32	24	22,8	37,8
1 1/2"	11,5	48,260	140	32	36	29	22,8	44
2"	11,5	60,325	160	36	45	35	23,2	56

CODICE - CODE	
E21CNPT...AZ	E21CNPT...AZ-VS
*	*
*	*
*	*
*	*
*	*
*	*
*	*
*	*
*	*
*	*

Ød1 NPT	P TPI	Ø mm	L ₁	L ₂	d ₂ h9	a h12	X	F*
1/16	27	7,938	90	13	6	4,9	9,3	6,2
1/8	27	10,287	90	13	7	5,5	9,3	8,5
1/4	18	13,716	100	20	11	9	13,5	11
3/8	18	17,145	110	20	12	9	13,9	14,5
1/2	14	21,336	125	26	16	12	18,1	17,9
3/4	14	26,670	140	26	20	16	18,6	23,2
1"	11,5	33,401	160	32	25	20	22,3	29
1 1/4"	11,5	42,164	160	32	32	24	22,8	37,8
1 1/2"	11,5	48,260	190	32	36	29	22,8	44
2"	11,5	60,325	200	36	45	35	23,2	56

CODICE - CODE	
E21LNPT...AZ	E21LNPT...AZ-VS
*	*
o	*
o	*
o	*
o	*
o	*
o	*
*	*
*	*
*	*

■ = Acciaio HSS / HSS Steel

* Diametri di foratura cilindrici.
Per alesatura conica vedi tabella pag. 258
 * Cilyndric hole.
For conic hole see on page 258

Confezione: Singola Box: Single	€ Pagina listino - Price list page	98	98	99	99
	● Standard	○ Disponibilità da richiedere, prezzo a listino		★ Solo a richiesta	
	● Standard	○ Lead time on enquiry, standard price-list		★ Only on request	

MASCHI A MACCHINA MACHINE TAPS

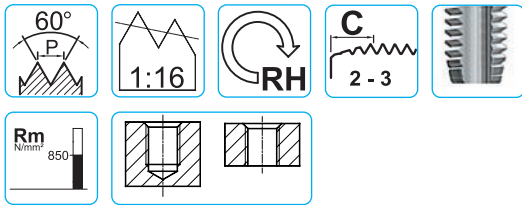
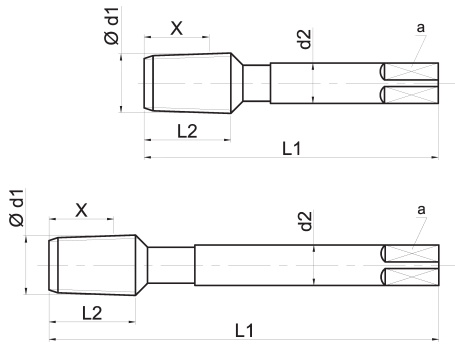

Profondità di filettatura - Thread depth	-	-	-	-
Materiale - Material	HSSE	HSSE	HSSE	HSSE
Tolleranza - Tolerance	-	-	-	-
Trattamento superficiale - Surface treatment	BR	VS	BR	VS
Numero gruppi materiali Material's groups number	1.1 1.2 1.3 1.4	1.1 1.2 1.3 1.4	1.1 1.2 1.3 1.4	1.1 1.2 1.3 1.4
	3.3 3.4 4.2 4.3	2.1 2.2 2.3	3.3 3.4 4.2 4.3	2.1 2.2 2.3
	5.3	3.1 3.2 3.3 3.4	5.3	3.1 3.2 3.3 3.4
		4.2 4.3 4.4 5.2 5.3		4.2 4.3 4.4 5.2 5.3

Ød1 NPTF	P TPI	Ø mm	L ₁	L ₂	d ₂ h9	a h12	X	F*
1/16	27	7,938	63	13	6	4,9	9,3	6,1
1/8	27	10,287	63	13	7	5,5	9,3	8,45
1/4	18	13,716	63	20	11	9	13,5	10,9
3/8	18	17,145	70	20	12	9	13,9	14,3
1/2	14	21,336	80	26	16	12	18,1	17,6
3/4	14	26,670	100	26	20	16	18,6	23,0
1"	11,5	33,401	110	32	25	20	22,3	28,75
1 1/4	11,5	42,164	125	32	32	24	22,8	37,5
1 1/2	11,5	48,260	140	32	36	29	22,8	43,75
2"	11,5	60,325	160	36	45	35	23,2	55,75

Ød1 NPTF	P TPI	Ø mm	L ₁	L ₂	d ₂ h9	a h12	X	F*
1/16	27	7,938	90	13	6	4,9	9,3	6,1
1/8	27	10,287	90	13	7	5,5	9,3	8,45
1/4	18	13,716	100	20	11	9	13,5	10,9
3/8	18	17,145	110	20	12	9	13,9	14,3
1/2	14	21,336	125	26	16	12	18,1	17,6
3/4	14	26,670	140	26	20	16	18,6	23,0
1"	11,5	33,401	160	32	25	20	22,3	28,75
1 1/4	11,5	42,164	160	32	32	24	22,8	37,5
1 1/2	11,5	48,260	190	32	36	29	22,8	43,75
2"	11,5	60,325	200	36	45	35	23,2	55,75

■ = Acciaio HSS / HSS Steel

CODICE - CODE	
E21CNPTF...	E21CNPTF...VS
*	*
o	*
o	*
o	*
o	*
o	*
o	*
o	*
o	*
o	*

CODICE - CODE	
E21LNPTF...	E21LNPTF...VS
*	*
o	*
o	*
o	*
o	*
o	*
o	*
*	*
*	*
*	*

* Diametri di foratura cilindrici.
Per alesatura conica vedi tabella pag. 258

* Cylindric hole.
For conic hole see on page 258

Confezione: Singola Box: Single	€ Pagina listino - Price list page	99	99	99	99
	● Standard	○ Disponibilità da richiedere, prezzo a listino	○ Lead time on enquiry, standard price-list	★ Solo a richiesta	★ Only on request

