



Il cliente UFS non è mai lasciato solo
UFS customers are never left alone

ASSISTANCE



L'AZIENDA E I SUOI PRODOTTI

Materiali impiegati

Used material

La resa di un utensile è determinata da un insieme di fattori, ma alla base di tutto vi è il materiale con cui è stato costruito l'utensile stesso. La UFS si avvale dei migliori acciai super rapidi ad alto contenuto di cobalto (5% ed oltre, oppure ad alta percentuale di Vanadio) e di acciai da polveri sinterizzate (PM, PM1, PM3 con alte % di Co e Co + Vanadio). Questi ultimi presentano una struttura molto più omogenea, con distribuzione finissima dei carburi, con corrispondente minor pericolo di scheggiatura, minor usura e ottime prestazioni sui materiali ad alta resistenza.

- Acciaio HSSE con 5% di Cobalto impiegato per materiali da lavorare con $R < 850 \text{ N/mm}^2$
- Acciaio HSSP con più alta percentuale di Cobalto impiegato per materiali da lavorare con $R < 1000 \text{ N/mm}^2$
- Acciaio HSSV3 con alta percentuale di Vanadio impiegato per INOX
- Acciai PM sinterizzati ad alto contenuto di Cobalto e Vanadio impiegato per materiali da lavorare con $R > 1000 \text{ N/mm}^2$

The tool yield is determined by several factors, but most fundamental is the material. UFS uses the best high speed steels of high cobalt content (5% and over, or a high percentage of vanadium) and steels made from sintered powders (PM, PM1, PM3 high % of Co and Co + Va). This materials show a more homogeneous structure, with low carbide content, and with a correspondingly reduced risk of splintering, less wear and better performance on materials of high resistance.

- HSSE steel with 5% of Cobalt used for materials to work with $R < 850 \text{ N/mm}^2$
- HSSP steels with higher Cobalt percentage (or vanadium) used for materials to work with $R < 1000 \text{ N/mm}^2$
- HSSV3 steel with high percentage of Vanadium, for Inox
- Sintered PM steels of a high cobalt and vanadium content used for materials to work with $R > 1000 \text{ N/mm}^2$



Trattamenti termici

Heat Treatments

Il trattamento termico è un fattore determinante per la resa dell'utensile e consiste in: **preriscaldi - tempra - rinvenimenti**. I preriscaldi sono graduali e la tempra è assistita da accuratissimi controlli della temperatura e dei tempi di austenitizzazione. Seguono 4-5 rinvenimenti per la trasformazione completa della struttura. Il controllo del grano austenitico avviene dopo l'austenitizzazione ed il controllo della durezza e della struttura dopo ogni singolo rinvenimento. Il trattamento termico viene eseguito in forni "sottovuoto" che garantiscono una tempra di alta qualità.

*Heat treatment is a conclusive factor for the yield of the tool and consists of **preheating - hardening - tempering**. The preheating is gradual and the tempering is assisted by very accurate controls of the temperature and the times of austenitisation. Then 4-5 recoveries follow for the complete transformation of the structure. The check of the austenitic grain occurs after the austenitisation and the hardness and the structure check after each recovery. Heat treatment are performed in vacuum ovens, which guarantee high quality tempering*

Qualità dei prodotti

Products' quality

I nostri controlli si basano da sempre su analisi metallografiche e dimensionali. Con la nuova realtà definita UFS Technology il prodotto, a campione, viene sottoposto a test di durata e a miglioramenti, specie per prodotti studiati su materiali particolari, a richiesta della Clientela.

Il personale dedicato lavora a tempo pieno sia sull'avanzamento prodotto UFS sia nella definizione delle nuove forme di utensili adatti a materiali nuovi o di dichiarato interesse in Progetti di Ricerca Europei, in collaborazione con il Politecnico di Torino - Facoltà di Scienza dei Materiali - e di altre simili ed importanti Facoltà Europee, tra cui Aachen e Bilbao.

Questo ci dà modo di sperimentare materiali di indubbia difficoltà, come le leghe ceramiche, ghise particolari, leghe aeronautiche e spaziali, per citarne alcune; i processi migliorativi definiti su tali materiali ci aiutano ad innalzare il livello qualitativo della normale produzione standard.

Our checks have always been based on metallographic and dimensional tests. Thanks to the new UFS Technology, the sample product subjected is tested for durability and improved, especially with products designed using special materials at the customer's request.

The staff appointed to these operations work full time both in UFS product improvement and in defining new tool shapes suitable for new materials or materials required for European Research Projects, together with Polytechnic University of Turin, Faculty of Materials Science as well as other important European Universities, including Aachen and Bilbao.

This allows us to test undoubtedly difficult materials, like ceramic alloys, special cast iron, aeronautical and space alloys, among others; the improvement processes established for these materials help us to raise the quality level of the standard production.

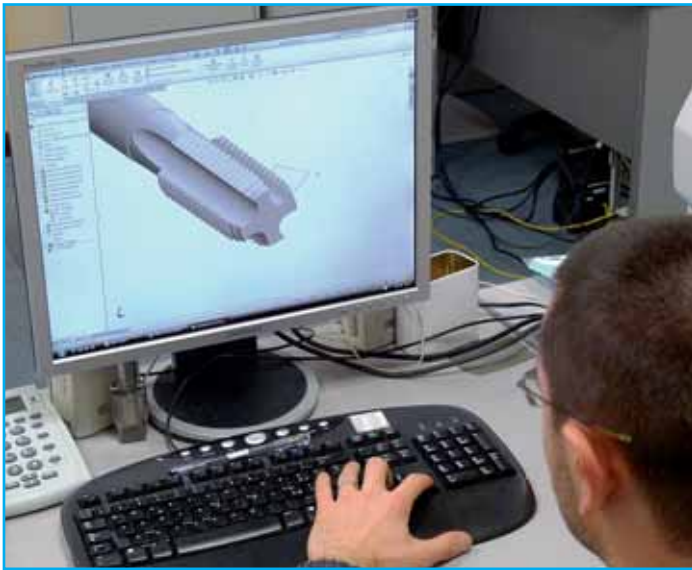

Obiettivi

Purposes

Gli obiettivi definiti nel precedente catalogo sono stati ampiamente raggiunti e nel corso di questi ultimi anni i processi di produzione stabilizzati ci hanno dato modo di innalzare la qualità e la ripetibilità del prodotto.

Non ci resta che confermare la rotta nella stessa direzione di miglioramento continuo, con la caparbia che ci accompagna.

The aims set out in our previous catalogue have been widely achieved and during these last few years the consolidated production processes have allowed us to increase product quality and repeatability. We only have to continue in this quest for continuous improvement, with our characteristic determination.

TERMINOLOGIA DEI MASCHI

TAP'S TERMINOLOGY

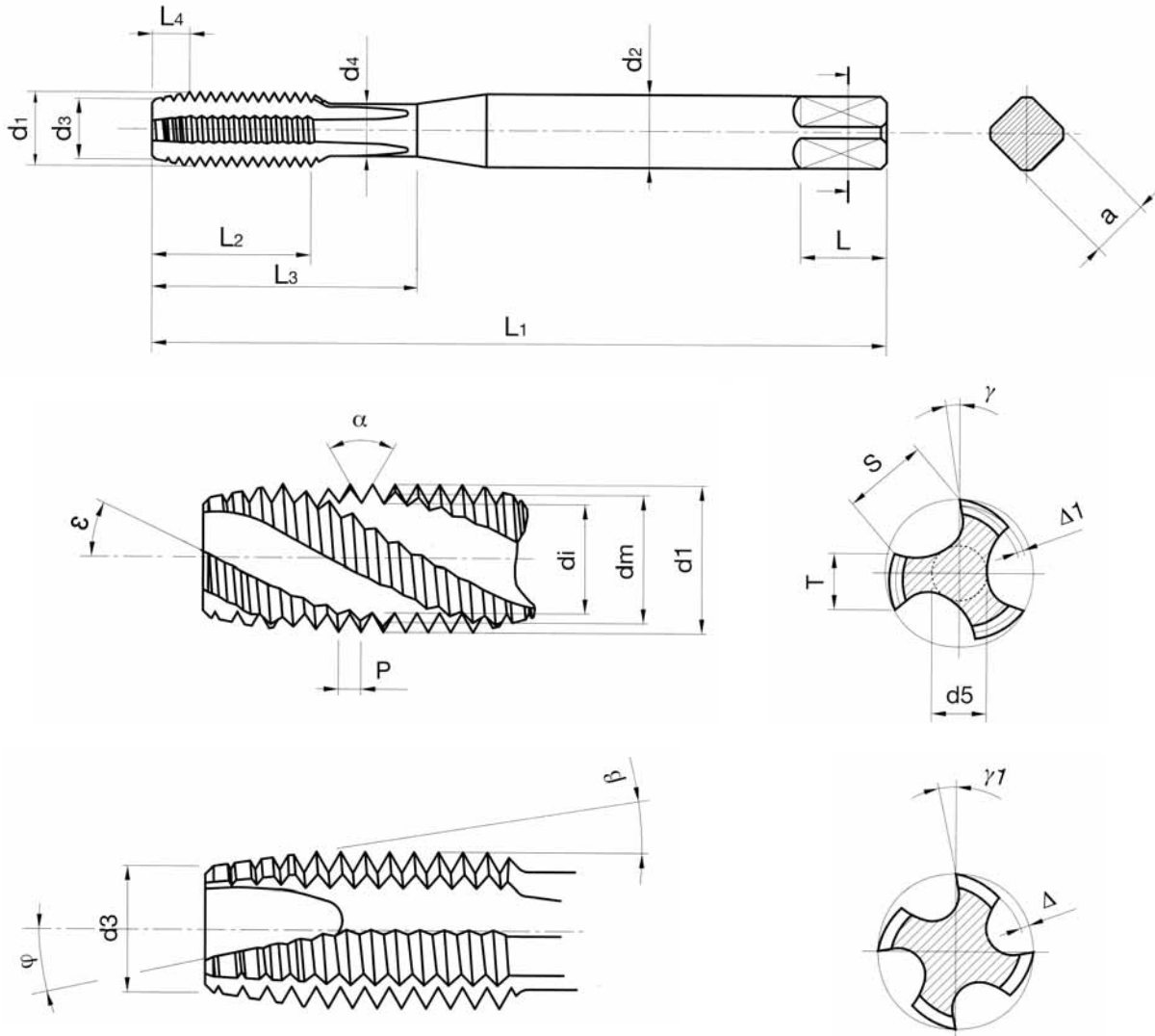

LEGENDA

LEGEND

- | | | |
|--|---|---|
| L1: Lunghezza totale – Total length | d2: Diametro del gambo – Shank diameter | γ_1: Angolo di taglio frontale – Rake angle |
| L2: Lunghezza filetto – Thread length | d4: Diametro del collarino – Neck diameter | γ: Angolo di taglio sull'imbocco corretto – Rake angle of spiral point |
| L4: Lunghezza imbocco – Chamfer length | d3: Diametro di imbocco – Chamfer diameter | β: Angolo di imbocco – Chamfer angle |
| L3: Lunghezza utile – Useful length | dm: Diametro medio – Pitch diameter | ϵ: Inclinazione dell'elica – Spiral flute angle |
| L: Lunghezza quadro – Length of square | di: Diametro interno – Minor diameter | Δ: Spoglia sull'imbocco – Chamfer relief |
| P: Passo – Pitch | d5: Diametro nucleo – Core diameter | Δ_1: Spoglia sul filetto – Pitch diameter relief |
| S: Larghezza scanalatura – Flute width | T: Larghezza del dente – Width of land | a: Quadro – Square |
| d1: Diametro est. nominale – Major diameter | α: Angolo del profilo – Included angle of thread | ϕ: Angolo inclinazione imbocco corretto – Spiral point angle |

TERMINOLOGIA FILIERE

DIES TERMINOLOGY

- d1:** Diametro nominale – Nominal diameter
d2: Diametro esterno – External diameter
h1: Spessore – Thickness

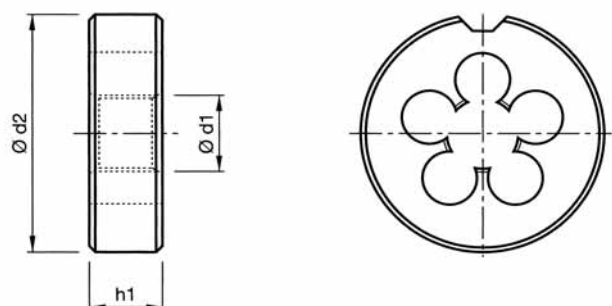

TIPI DI FORO E RELATIVI MASCHI CONSIGLIATI

HOLE TYPES AND RECOMMENDED TAPS

Fori ciechi e passanti

Blind and through holes

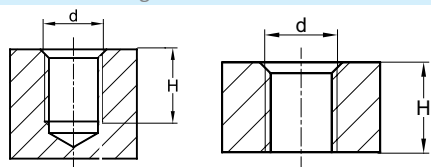

$H < 1,5 d$

E20



Fori passanti

Through holes

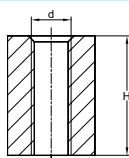

$H < 3 d$

E24

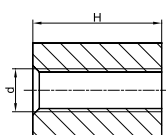

$H < 3 d$

E50



Fori ciechi

Blind holes

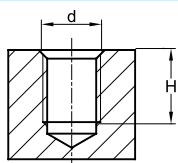

$H < 1,5 d$

E40

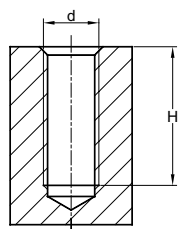

$H < 2,5 d$

E60



$H 2,5 \div 3 d$

E80



BT= Back Tapered
Rastremazione posteriore del filetto

$H > 3 d$

E82



TIPI DI IMBOCCO

CHAMFER'S TYPE

Lunghezza
Length
n° x P

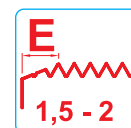
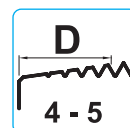
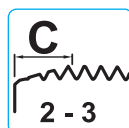
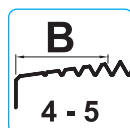
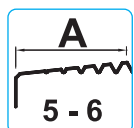

PREFORI DI MASCHIATURA PER MASCHI AD ASPORTAZIONE

TAPPING DRILL SIZES FOR CUTTING TAPS

Filettatura metrica ISO DIN 13

ISO Metric coarse thread DIN 13

M	P mm		Ø di foratura 6H - drill sizes	
			min	max
*M 1	0,25	0,75	0,729	0,785
*M 1,1	0,25	0,85	0,829	0,885
*M 1,2	0,25	0,95	0,929	0,985
*M 1,4	0,30	1,10	1,075	1,142
M 1, 6	0,35	1,25	1,221	1,321
M 1,70	,35	1,35	1,321	1,421
M 1,8	0,35	1,45	1,421	1,521
M 2	0,40	1,60	1,567	1,679
M 2,2	0,45	1,75	1,713	1,838
M 2,3	0,4	1,90	1,813	1,938
M 2,5	0,45	2,05	2,013	2,138
M 2,6	0,45	2,10	2,113	2,238
M 3	0,50	2,50	2,459	2,599
M 3,5	0,60	2,90	2,850	3,010
M 4	0,70	3,30	3,242	3,422
M 4, 5	0,75	3,70	3,688	3,878
M 5	0,80	4,20	4,134	4,334
M 6	1,00	5,00	4,917	5,153
M 7	1,00	6,00	5,917	6,153
M 8	1,25	6,80	6,647	6,912
M 9	1,25	7,80	7,647	7,912
M 10	1,50	8,50	8,376	8,676
M 11	1,50	9,50	9,376	9,676
M 12	1,75	10,30	10,106	10,441
M 14	2,00	12,00	11,835	12,210
M 16	2,00	14,00	13,835	14,210
M 18	2,50	15,50	15,294	15,744
M 20	2,50	17,50	17,294	17,744
M 22	2,50	19,50	19,294	19,744
M 24	3,00	21,00	20,752	21,252
M 27	3,00	24,00	23,752	24,252
M 30	3,50	26,50	26,211	26,771
M 33	3,50	29,50	29,211	29,771
M 36	4,00	32,00	31,670	32,270
M 39	4,00	35,00	34,670	35,270
M 42	4,50	37,50	37,129	37,799
M 45	4,50	40,50	40,129	40,799
M 48	5,00	43,00	42,587	43,297
M 52	5,00	47,00	46,587	47,297
M 56	5,50	50,50	50,046	50,796
M 60	5,50	54,50	54,046	54,796
M 64	6,00	58,00	57,505	58,308
M 68	6,00	62,00	61,505	62,305

* Tolleranza, tolerance: 5H

Filettatura MJ, MJ thread

DIN ISO 5855

MJ	P mm		Ø di foratura 5H - drill sizes	
			min	max
*MJ 3	0,50	2,60	2,513	2,653
*MJ 4	0,70	3,40	3,318	3,498
*MJ 5	0,80	4,30	4,221	4,421
MJ 6	1	5,10	5,026	5,216
MJ 8	1	7,10	7,026	7,216
MJ 8	1,25	6,90	6,782	6,994
MJ 10	1	9,10	9,026	9,216
MJ 10	1,25	8,90	8,782	8,994
MJ 10	1,5	8,60	8,539	8,775
MJ 12	1,25	10,90	10,782	10,994
MJ 12	1,5	10,60	10,539	10,775
MJ 12	1,75	10,40	10,295	10,560
MJ 14	1,5	12,60	12,539	12,775
MJ 14	2	12,20	12,051	12,351
MJ 16	1,5	14,60	14,539	14,775
MJ 16	2	14,20	14,051	14,351

* Tolleranza, tolerance: 6H



Importante: fate attenzione al diametro di foratura

Important: pay attention to the drills' diameter

PREFORI DI MASCHIATURA PER MASCHI AD ASPORTAZIONE

TAPPING DRILL SIZES FOR CUTTING TAPS

Filettatura metrica ISO passo fine DIN 13

ISO metric fine thread DIN 13

MF	P mm		Ø di foratura 6H - drill sizes	
			min	max
M 4	0,5	3,50	3,459	3,599
M 4,5	0,5	4,00	3,959	4,099
M 5	0,5	4,50	4,459	4,599
M 6	0,5	5,50	5,459	5,599
M 6	0,75	5,25	5,188	5,378
M 7	0,75	6,25	6,188	6,378
M 8	0,5	7,50	7,459	7,599
M 8	0,75	7,25	7,188	7,378
M 8	1	7,00	6,917	7,153
M 9	0,75	8,25	8,188	8,378
M 9	1	8,00	7,917	8,153
M 10	0,5	9,50	9,459	9,599
M 10	0,75	9,25	9,188	9,378
M 10	1	9	8,917	9,153
M 10	1,25	8,75	8,647	8,912
M 11	1	10	9,917	10,153
M 12	0,5	11,5	11,459	11,599
M 12	0,75	11,25	11,188	11,378
M 12	1	11	10,917	11,153
M 12	1,25	10,75	10,647	10,912
M 12	1,5	10,5	10,376	10,676
M 13	1	12	11,917	12,153
M 14	1	13	12,917	13,153
M 14	1,25	12,75	12,647	12,912
M 14	1,5	12,5	12,376	12,676
M 15	1	14	13,917	14,153
M 15	1,5	13,5	13,376	13,676
M 16	1	15	14,917	15,153
M 16	1,25	14,8	14,647	14,912
M 16	1,5	14,5	14,376	14,676
M 17	1	16	15,917	16,153
M 17	1,5	15,5	15,376	15,676
M 18	1	17	16,917	17,153
M 18	1,5	16,5	16,376	16,676
M 18	2	16	15,835	16,210
M 20	1	19	18,917	19,153
M 20	1,5	18,5	18,376	18,676
M 20	2	18	17,835	18,210
M 22	1	21	20,917	21,153
M 22	1,5	20,5	20,376	20,676
M 22	2	20	19,835	20,210
M 24	1	23	22,917	23,153
M 24	1,5	22,5	22,376	22,676
M 24	2	22	21,835	22,210
M 25	1	24	23,917	24,153
M 25	1,5	23,5	23,376	23,676
M 25	2	23	22,835	23,210
M 26	1,5	24,5	24,376	24,676
M 27	1	26	25,917	26,153
M 27	1,5	25,5	25,376	25,676
M 27	2	25	24,835	25,210

Filettatura metrica ISO passo fine DIN 13

ISO metric fine thread DIN 13

MF	P mm		Ø di foratura 6H - drill sizes	
			min	max
M 28	1	27	26,917	27,153
M 28	1,5	26,5	26,376	26,676
M 28	2	26	25,835	26,210
M 30	1	29	28,917	29,153
M 30	1,5	28,5	28,376	28,676
M 30	2	28	27,835	28,210
M 30	3	27	26,752	27,252
M 32	1,5	30,5	30,376	30,676
M 32	2	30	29,835	30,210
M 33	1,5	31,5	31,376	31,676
M 33	2	31	30,835	31,210
M 33	3	30	29,752	30,252
M 34	1,5	32,5	32,376	32,676
M 35	1,5	33,5	33,376	33,676
M 36	1,5	34,5	34,376	34,676
M 36	2	34	33,835	34,210
M 36	3	33	32,752	33,252
M 38	1,5	36,5	36,376	36,676
M 39	1,5	37,5	37,376	37,676
M 39	2	37	36,835	37,210
M 39	3	36	35,752	36,252
M 40	1,5	38,5	38,376	38,676
M 40	2	38	37,835	38,210
M 40	3	37	36,752	37,252
M 42	1,5	40,5	40,376	40,676
M 42	2	40	39,835	40,210
M 42	3	39	38,752	39,252
M 42	4	38	37,670	38,270
M 45	1,5	43,5	43,376	43,676
M 45	2	43	42,835	43,210
M 45	3	42	41,752	42,252
M 45	4	41	40,670	41,270
M 48	1,5	46,5	46,376	46,676
M 48	2	46	45,835	46,210
M 48	3	45	44,752	45,252
M 48	4	44	43,670	44,270
M 50	1,5	48,5	48,376	48,676
M 50	2	48	47,835	48,210
M 50	3	47	46,752	47,252
M 52	1,5	50,5	50,376	50,676
M 52	2	50	49,835	50,210
M 52	3	47	46,587	47,087
M 52	4	48	47,670	48,270
M 55	1,5	53,5	53,376	53,676
M 55	2	53	52,835	53,210
M 55	3	52	51,752	52,252
M 55	4	51	50,670	51,270
M 56	1,5	54,5	54,376	54,676
M 56	2	54	53,835	54,210
M 56	3	53	52,752	53,252
M 56	4	52	51,670	52,270

PREFORI DI MASCHIATURA PER MASCHI AD ASPORTAZIONE

TAPPING DRILL SIZES FOR CUTTING TAPS

Filettatura metrica ISO passo fine DIN 13

ISO metric fine thread DIN 13

MF	P mm		Ø di foratura 6H - drill sizes	
			min	max
M 58	1,5	56,5	56,376	56,676
M 58	2	56	55,835	56,210
M 58	3	55	54,752	55,252
M 58	4	54	53,670	54,270
M 60	1,5	58,5	58,376	58,676
M 60	2	58	57,835	58,210
M 60	3	57	56,752	57,252
M 60	4	56	55,670	56,270
M 62	1,5	60,5	60,376	60,676
M 62	2	60	59,835	60,210
M 62	3	59	58,752	59,252
M 62	4	58	57,670	58,270
M 64	1,5	62,5	62,376	62,676
M 64	2	62	61,835	62,210
M 64	3	61	60,752	61,252
M 64	4	60	59,670	60,270
M 65	1,5	63,5	63,376	63,676
M 65	2	63	62,835	63,210
M 65	3	62	61,752	62,252
M 65	4	61	60,670	61,270
M 68	1,5	66,5	66,376	66,676
M 68	2	66	65,835	66,210
M 68	3	65	64,752	65,252
M 68	4	64	63,670	64,270
M 70	1,5	68,5	68,376	68,676
M 70	2	68	67,835	68,210
M 70	3	67	66,752	67,252
M 70	4	66	65,670	66,270
M 70	6	64	63,505	64,305
M 72	1,5	70,5	70,376	70,676
M 72	2	70	69,835	70,210
M 72	3	69	68,752	69,252
M 72	4	68	67,670	68,270
M 72	6	66	65,505	66,305
M 75	1,5	73,5	73,376	73,676
M 75	2	73	72,835	73,210
M 75	3	72	71,752	72,252
M 75	4	71	70,670	71,270
M 76	1,5	74,5	74,376	74,676
M 76	2	74	73,835	74,210
M 76	3	73	72,752	73,252
M 76	4	72	71,670	72,270
M 76	6	70	69,505	70,305
M 80	1,5	78,5	78,376	78,676
M 80	2	78	77,835	78,210
M 80	3	77	76,752	77,252
M 80	4	76	75,670	76,270
M 80	6	74	73,505	74,305
M 85	2	83	82,835	83,210
M 85	3	82	81,752	82,252
M 85	4	81	80,670	81,270
M 85	6	79	78,505	79,305

Filettatura americana UNC ASME B1.1

UNC coarse thread ASME B1.1

UNC	P TPI		Ø di foratura 2B - drill sizes	
			min	max
Nr. 6	32	2,85	2,642	2,896
Nr. 8	32	3,50	3,302	3,531
Nr. 10	24	3,90	3,683	3,937
Nr. 12	24	4,50	4,343	4,597
1/4	20	5,10	4,978	5,258
5/16	18	6,60	6,401	6,731
3/8	16	8,00	7,798	8,153
7/16	14	9,40	9,144	9,550
1/2	13	10,80	10,592	11,024
9/16	12	12,20	11,989	12,446
5/8	11	13,50	13,386	13,868
3/4	10	16,50	16,307	16,840
7/8	9	19,50	19,177	19,761
1"	8	22,25	21,971	22,606
1"-1/8	7	25,00	24,638	25,349
1"-1/4	7	28,00	27,813	28,524
1"-3/8	6	30,75	30,353	31,155
1"-1/2	6	34,00	33,528	34,290
1"-3/4	5	39,50	38,938	39,802
2"	4,5	45,00	44,679	45,593

Filettatura UNJC, UNJC thread

ASME B1.15

UNJC	P TPI		Ø di foratura 3B - drill sizes	
			min	max
Nr. 6	32	2,80	2,733	2,939
Nr. 8	32	3,50	3,393	3,599
Nr. 10	24	3,90	3,795	4,064
Nr. 12	24	4,60	4,455	4,704
1/4	20	5,20	5,113	5,387
5/16	18	6,70	6,563	6,833
3/8	16	8,10	7,978	8,255
7/16	14	9,50	9,347	9,639
1/2	13	10,90	10,798	11,095
9/16	12	12,35	12,228	12,482
5/8	11	13,80	13,627	13,904
3/4	10	16,70	16,576	16,881

PREFORI DI MASCHIATURA PER MASCHI AD ASPORTAZIONE

TAPPING DRILL SIZES FOR CUTTING TAPS

Filettatura americana UNF ASME B1.1

UNF fine thread ASME B1.1

UNF	P TPI		Ø di foratura 2B - drill sizes	
			min	max
Nr. 6	40	2,95	2,819	3,023
Nr. 8	36	3,50	3,404	3,607
Nr. 10	32	4,10	3,962	4,166
Nr. 12	28	4,60	4,469	4,724
1/4	28	5,50	5,359	5,588
5/16	24	6,90	6,782	7,036
3/8	24	8,50	8,382	8,636
7/16	20	9,90	9,728	10,033
1/2	20	11,50	11,328	11,608
9/16	18	12,90	12,751	13,081
5/8	18	14,50	14,351	14,681
3/4	16	17,50	17,323	17,678
7/8	14	20,40	20,269	20,676
1"	12	23,25	23,114	23,571
1"-1/8	12	26,50	26,289	26,746
1"-1/4	12	29,50	29,464	29,921
1"-3/8	12	32,75	32,639	33,096
1"-1/2	12	36,00	35,814	36,271

Filettatura americana UNEF ASME B1.1

UNEF extra fine thread ASME B1.1

UNEF	P TPI		Ø di foratura 2B - drill sizes		
			min	max	
1/4 32	5,55	5,487	5,690		
5/16 32	7,15	7,087	7,264		
3/8 32	8,7	8,662	8,865		
7/16 28	10,2	10,135	10,338		
1/2 28	11,8	11,710	11,938		
9/16 24	13,2	13,132	13,386		
5/8 24	14,8	14,732	14,986		
11/16 24	16,4	16,307	16,561		
3/4 20	17,8	17,679	17,958		
13/16 20	19,4	19,254	19,558		
7/8 20	20,95	20,854	21,133		
15/16 20	22,50	22,429	22,733		
1" 20	24,15	24,029	24,308		
1"-1/16	18	25,6	25,451	25,781	
1"-1/8	18	27,15	27,051	27,381	
1"-3/16	18	28,75	28,626	28,956	
1"-1/4	18	30,3	30,226	30,556	
1"-3/8	18	33,5	33,401	33,731	
1"-7/16	18	35,1	34,976	35,306	
1"-1/2	18	36,7	36,576	36,881	

Filettatura UNJF, UNJF thread

ASME B1.15

UNJF	P TPI		Ø di foratura 3B - drill sizes	
			min	max
Nr. 6	40	2,95	2,888	3,053
Nr. 8	36	3,6	3,480	3,663
Nr. 10	32	4,15	4,054	4,255
Nr. 12	28	4,7	4,602	4,816
1/4	28	5,6	5,466	5,662
5/16	24	7	6,906	7,109
3/8	24	8,6	8,494	8,679
7/16	20	10	9,876	10,084
1/2	20	11,55	11,463	11,661
9/16	18	13	12,913	13,122
5/8	18	14,6	14,501	14,702
3/4	16	17,6	17,506	17,722

Filettatura americana 8-UN ASME B1.1

8-UN thread ASME B1.1

8-UN	P TPI		Ø di foratura 2B - drill sizes		
			min	max	
1"-1/8	8	25,4	25,146	25,781	
1"-1/4	8	28,6	28,321	28,956	
1"-3/8	8	31,75	31,496	32,131	
1"-1/2	8	34,9	34,671	35,306	
1"-5/8	8	38,1	37,846	38,481	
1"-3/4	8	41,3	41,021	41,656	
1"-7/8	8	44,45	44,196	44,831	
2"	8	47,6	47,371	48,006	
2"-1/4	8	54	53,721	54,356	
2"-1/2	8	60,30	60,071	60,706	

PREFORI DI MASCHIATURA PER MASCHI AD ASPORTAZIONE

TAPPING DRILL SIZES FOR CUTTING TAPS

Filettatura GAS Whitworth DIN EN ISO 228

Whitworth pipe thread DIN EN ISO 228

GAS	P TPI		Ø di foratura - drill sizes	
			min	max
1/8	28	8,8	8,566	8,848
1/4	19	11,8	11,445	11,890
3/8	19	15,25	14,950	15,395
1/2	14	19	18,631	19,172
5/8	14	21	20,587	21,128
3/4	14	24,5	24,117	24,658
7/8	14	28,25	27,877	28,418
1"	11	30,75	30,291	30,931
1" 1/8	11	35,5	34,939	35,579
1" 1/4	11	39,5	38,952	39,592
1" 1/2	11	45,25	44,845	45,485
1" 3/4	11	51,10	50,788	51,428
2"	11	57	56,656	57,296
2" 1/4	11	63,10	62,752	63,392
2" 1/2	11	72,6	72,226	72,866
2" 3/4	11	79	78,576	79,216
3"	11	85,3	84,926	85,566

Filettatura gas cilindrica americana sec. ANSI B1.20.1

American Standard straight pipe thread acc. ANSI B1.20.1

NPSM (NPSC)	P TPI		Ø di foratura - drill sizes	
			NPSM	NPSC
1/8	27		9,10	8,8
1/4	18		12	11,40
3/8	18		15,5	14,8
1/2	14		19	18,5
3/4	14		24,5	23,8
1"	11,5		30,5	29,9

Filettatura gas cilindrica americana sec. ANSI B1.20.3

American Standard straight pipe thread acc. ANSI B1.20.3

NPSF	P TPI		Ø di foratura - drill sizes	
			min	max
1/8	27	8,7	8,651	
1/4	18	11,30	11,232	
3/8	18	14,7	14,671	
1/2	14	18,2	18,118	
3/4	14	23,50	23,465	
1"	11,5	29,50	29,464	

Filettatura interna GAS cilindrica Whitworth ISO 7-1

Cylindrical Whitworth internal pipe thread ISO 7-1

Rp	P TPI		Ø di foratura - drill sizes	
			min	max
1/8	28	8,6	8,495	8,637
1/4	19	11,5	11,341	11,549
3/8	19	15	14,846	15,054
1/2	14	18,5	18,489	18,773
3/4	14	24	23,975	24,259
1"	11	30,25	30,111	30,471
1" 1/4	11	39	38,772	39,132
1" 1/2	11	45	44,665	45,025
2"	11	56,5	56,476	56,836

Filettatura GAS Whitworth DIN EN ISO 228

Whitworth pipe thread DIN EN ISO 228

BSW	P TPI		Ø di foratura - drill sizes	
			min	max
1/8	40	2,5	2,362	2,591
3/16	24	3,6	3,407	3,745
1/4	20	5	4,724	5,156
5/16	18	6,5	6,130	6,590
3/8	16	7,9	7,492	7,987
7/16	14	9,2	8,789	9,330
1/2	12	10,5	9,989	10,591
9/16	12	12	11,577	12,179
5/8	11	13,4	12,918	13,558
3/4	10	16,4	15,797	16,483
7/8	9	19,25	18,611	19,353
1"	8	22	21,334	22,147
1" 1/8	7	24,75	23,928	24,832
1" 1/4	7	27,5	27,103	28,007
1" 1/2	6	33,5	32,679	33,703

PREFORI DI MASCHIATURA PER MASCHI AD ASPORTAZIONE

TAPPING DRILL SIZES FOR CUTTING TAPS

Filettatura per tubi corazzati DIN 40430

Steel conduit thread DIN 40430

PG	P TPI		Ø di foratura - drill sizes	
			min	max
PG 7	20	11,4	11,28	11,43
PG 9	18	14	13,86	14,01
PG 11	18	17,25	17,26	17,41
PG 13,5	18	19	19,06	19,21
PG 16	18	21,25	21,16	21,31
PG 21	16	27	26,78	27,03
PG 29	16	35,5	35,48	35,73
PG 36	16	45,5	45,48	45,73
PG 42	16	52,5	52,48	52,73
PG 48	16	58	57,78	58,03

Filettatura tonda DIN 405

Round thread DIN 405

Rd	P TPI		Ø di foratura - drill sizes	
			min	max
8	10	6	5,714	6,274
9	10	7	6,714	7,274
10	10	8	7,714	8,274
11	10	9	8,714	9,274
12	10	10	9,714	10,274
14	8	11,5	11,142	11,812
16	8	13,5	13,142	13,812
18	8	15,5	15,142	15,812
20	8	17,5	17,142	17,812
22	8	19,5	19,142	19,812
24	8	21,5	21,142	21,812
26	8	23,5	23,142	23,812
28	8	25,5	25,142	25,812
30	8	27,5	27,142	27,812

Filettatura ISO metrica trapezoidale DIN 103

ISO Metric trapezoidal thread DIN 103

TR	P mm		Ø di foratura - drill sizes	
			min	max
10	2	8,2	8,000	8,236
10	3	7,5	-	-
12	2	10,2	10,000	10,236
12	3	9,25	9,000	9,315
14	3	11,25	11,000	11,315
14	4	10,5	-	-
16	4	12,25	12,000	12,375
18	4	14,25	14,000	14,375
20	4	16,25	16,000	16,375
22	5	17,25	17,000	17,450
24	5	19,25	19,000	19,450
26	5	21,25	21,000	21,450
28	5	23,25	23,000	23,450
30	6	24,25	24,000	24,500
32	6	26,25	26,000	26,500
36	6	30,25	30,000	30,500

Filettatura ISO metrica DIN 8140-2 per filetti riportati

ISO Metric coarse thread DIN 8140-2 for wire thread inserts (STI)

EGM	P mm		Ø di foratura - drill sizes	
			min	max
2	0,4	2,10	2,087	2,177
2,5	0,45	2,65	2,597	2,697
3	0,5	3,15	3,108	3,22
3,5	0,6	3,70	3,630	3,755
4	0,7	4,20	4,152	4,292
5	0,8	5,25	5,174	5,344
6	1	6,30	6,217	6,407
7	1	7,30	7,217	7,407
8	1,25	8,40	8,217	8,483
9	1,25	9,40	9,217	9,483
10	1,5	10,50	10,324	10,560
11	1,5	11,50	11,324	11,560
12	1,75	12,50	12,379	12,644
14	2	14,50	14,433	14,733
16	2	16,50	16,433	16,733
18	2,5	18,75	18,541	18,986
20	2,5	20,75	20,541	20,896

PREFORI PER MASCHIATURA CONICA

TAPPING DRILL SIZES FOR CONICAL THREADING

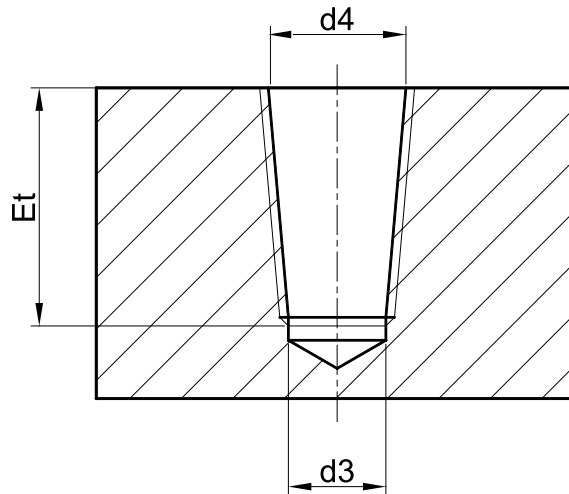

Filettatura gas conica americana, conicità 1:16 sec. ANSI/ASME B1.20.1
 American tapered pipe thread, taper 1:16 acc. ANSI/ASME B1.20.1

NPT

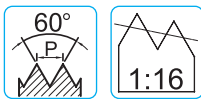

Ød1	P TPI	d3 cil./cyl. mm	d4 con./taper mm	Et = X
1/16	27	6,20	6,39	9,30
1/8	27	8,50	8,74	9,30
1/4	18	11	11,36	13,50
3/8	18	14,50	14,80	13,90
1/2	14	17,9	18,32	18,10
3/4	14	23,2	23,67	18,60
1"	11,5	29,00	29,69	22,30
1"1/4	11,5	37,8	38,45	22,80
1"1/2	11,5	44	44,52	22,80
2"	11,5	56	56,56	23,20

Filettatura gas conica americana, conicità 1:16 sec. ANSI/ASME B1.20.3
 American tapered pipe thread, taper 1:16 acc. ANSI/ASME B1.20.3

NPTF

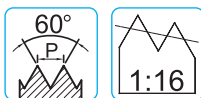

Ød1	P TPI	d3 cil./cyl. mm	d4 con./taper mm	Et = X
1/16	27	6,10	6,41	9,30
1/8	27	8,45	8,76	9,30
1/4	18	10,9	11,4	13,50
3/8	18	14,3	14,84	13,90
1/2	14	17,6	18,33	18,10
3/4	14	23,0	23,68	18,60
1"	11,5	28,75	29,72	22,30
1"1/4	11,5	37,5	38,48	22,80
1"1/2	11,5	43,75	44,55	22,80
2"	11,5	55,75	56,59	23,20

Filettatura gas conica Whitworth, conicità 1:16, ISO 7-1
 Tapered Whitworth pipe thread, taper 1:16, ISO 7-1

Rc

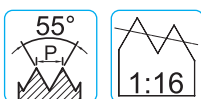

Ød1	P TPI	d3 cil./cyl. mm	d4 con./taper mm	Et = X
1/8	28	8,20	8,57	10,1
1/4	19	11	11,45	15,0
3/8	19	14,5	14,95	15,4
1/2	14	18	18,63	20,4
3/4	14	23,5	24,12	21,7
1"	11	29,5	30,29	26
1"1/4	11	38	38,95	28,3
1"1/2	11	44	44,85	28,3
2"	11	55,5	56,66	32,6

PREFORI DI MASCHIATURA PER MASCHI A RULLARE

TAPPING DRILL SIZES FOR ROLLING TAPS

Filettatura metrica ISO DIN 13

ISO metric coarse thread DIN 13

M	P mm		Toll.
2	0,4	1,82	± 0,02
2,2	0,45	2,00	± 0,02
2,3	0,4	2,1	± 0,02
2,5	0,45	2,30	± 0,02
2,6	0,45	2,40	± 0,02
3	0,5	2,8	± 0,03
3,5	0,6	3,25	± 0,03
4	0,7	3,70	± 0,03
5	0,8	4,65	± 0,03
6	1	5,55	± 0,05
8	1,25	7,40	± 0,05
10	1,5	9,30	± 0,05
12	1,75	11,20	± 0,05
14	2	13,10	± 0,05
16	2	15,10	± 0,05
18	2,5	16,90	± 0,05
20	2,5	18,90	± 0,05
22	2,5	20,90	± 0,05
24	3	22,70	± 0,05

Filettatura metrica ISO passo fine DIN 13

ISO metric fine thread DIN 13

MF	P mm		Toll.
4	0,5	3,80	±0,03
5	0,5	4,80	±0,03
6	0,5	5,80	±0,03
6	0,75	5,65	±0,03
8	1	7,55	±0,05
10	1	9,55	±0,05
10	1,25	9,40	±0,05
12	1	11,55	±0,05
12	1,25	11,40	±0,05
12	1,5	11,30	±0,05
14	1	13,55	±0,05
14	1,25	13,40	±0,05
14	1,5	13,30	±0,05
16	1	15,55	±0,05
16	1,25	15,40	±0,05
16	1,5	15,30	±0,05
18	1	17,55	±0,05
18	1,25	17,40	±0,05
18	1,5	17,30	±0,05
20	1	19,55	±0,05
20	1,25	19,40	±0,05
20	1,5	19,30	±0,05
20	2	19,10	±0,05
22	1	21,55	±0,05
22	1,25	21,40	±0,05
22	1,5	21,30	±0,05
22	2	21,10	±0,05
24	1	23,55	±0,05
24	1,25	23,40	±0,05
24	1,5	23,30	±0,05
24	2	23,10	±0,05
26	1,5	25,30	±0,05
26	2	25,10	±0,05
27	1,5	26,30	±0,05
27	2	26,10	±0,05
28	1,5	27,30	±0,05
28	2	27,10	±0,05
30	1,5	29,30	±0,05
30	2	29,10	±0,05



Attenzione! I diametri di foratura per rullare sono diversi da quelli standard!

Attention! Drills' diameters for roll taps are different from standard ones!

PREFORI DI MASCHIATURA PER MASCHI A RULLARE

TAPPING DRILL SIZES FOR ROLLING TAPS

Filettatura americana UNC ASME B1.1

UNC coarse thread ASME B1.1

UNC	P TPI		Toll.
6	32	3,15	±0,03
8	32	3,80	±0,03
10	24	4,30	±0,05
12	24	5,00	±0,05
1/4	20	5,75	±0,05
5/16	18	7,25	±0,05
3/8	16	8,75	±0,05
7/16	14	10,30	±0,05
1/2	13	11,80	±0,05
9/16	12	13,30	±0,05
5/8	11	14,80	±0,05
3/4	10	17,9	±0,05
7/8	9	21	±0,05
1'	8	24	±0,05

Filettatura americana UNF ASME B1.1

UNF fine thread ASME B1.1

UNF	P TPI		Toll.
6	40	3,20	±0,03
8	36	3,85	±0,03
10	32	4,45	±0,03
12	28	5,05	±0,05
1/4	28	5,90	±0,05
5/16	24	7,45	±0,05
3/8	24	9,00	±0,05
7/16	20	10,50	±0,05
1/2	20	12,10	±0,05
9/16	18	13,70	±0,05
5/8	18	15,25	±0,05
3/4	16	18,40	±0,05
7/8	14	21,40	±0,05
1'	12	24,45	±0,05
1'-1/8	12	27,60	±0,05
1'-1/4	12	30,80	±0,05
1'-3/8	12	34,00	±0,05
1'-1/2	12	37,15	±0,05

Filettatura GAS Whitworth DIN EN ISO 228

Whitworth pipe thread DIN EN ISO 228

GAS	P TPI		Toll.
1/16	28	7,25	±0,05
1/8	28	9,25	±0,05
1/4	19	12,5	±0,05
3/8	19	16	±0,05
1/2	14	20	±0,05
5/8	14	22	±0,05
3/4	14	25,5	±0,05
7/8	14	29,25	±0,05
1'	11	32	±0,05
1'-1/8	11	36,70	±0,05
1'-1/4	11	40,70	±0,05

CLASSI DI TOLLERANZA DEI MASCHI

TOLERANCE CLASSES OF TAPS

ISO	Maschio/Tap DIN	ANSI/ASME	Madrevite Internal thread, nut				Accoppiamento Fit	
ISO 1	4H	3B	4H	5H			Senza gioco Fit without allowance	
ISO 2	6H	2B	4G	5G	6H		Con gioco standard Standard fit	
ISO 3	6G	1B			6G	7H	8H	Con gioco speciali Special fit with allowance
	7G					7G	8G	Largo per successivi rivestimenti Loose fit, for subsequent coating

Posizione della tolleranza

Tolerance classes

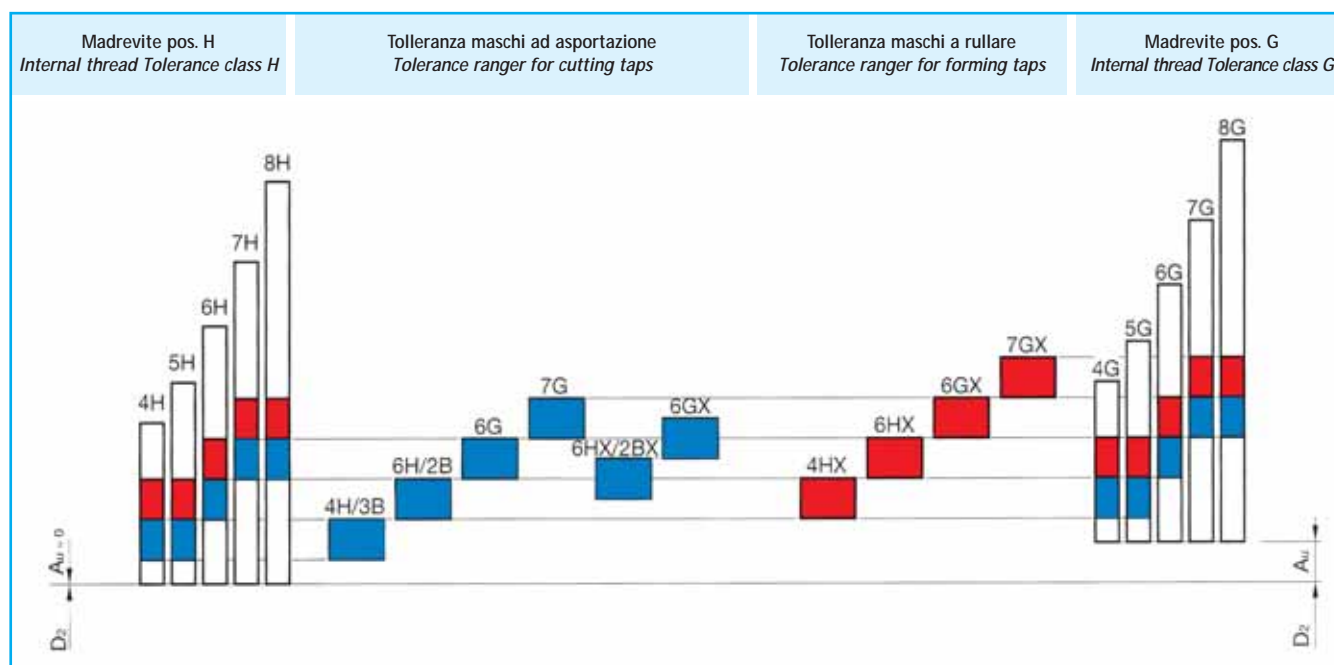

L'accoppiamento più comunemente utilizzato è quello relativo alle classe ISO 2, 6H o 2B. Per accoppiamenti più precisi, senza gioco tra i fianchi del filetto, deve essere utilizzato un accoppiamento "più stretto" di classe ISO 1, 4H o 3B.

Le tolleranze ISO 3, 6G o 1B sono utilizzate per accoppiamenti grossolani, applicate nel caso di ricoprimenti superficiali successivi al processo di filettatura.

Standard fit for a thread is according tolerance ISO 2, 6H or 2B and so, for more precise fit, without any allowance on thread flanks, You have to choose ISO 1, 4H and 3B, for American threading.

For following coatings to be applied after threading You have to use ISO 3, 6G, 1B.

Vengono inoltre realizzate tolleranze intermedie 6HX e 6GX applicate su tipologie di maschi che lavorano materiali abrasivi, come la ghisa, per aumentare la durata. Un'altra applicazione delle tolleranze intermedie X è quella relativa ai maschi a rullare, che realizzano la filettatura mediante processo di deformazione plastica; in questo caso, ad esempio, per ottenere una filettatura 6H il maschio viene realizzato in tolleranza 6HX per compensare il ritorno elastico del materiale lavorato.

Taps'manufacturers produce taps with tolerance 6HX and 6GX and not only 6H and 6G. These taps are used for cast iron, to increase tools'life or for forming taps. In those cases You have to use 6HX tap to compensate the elastic return of the material.

Nelle pagine successive sono riportati gli scostamenti standard (6H e 2B) per le filettature M, MF,UNC, UNF e GAS. ➤

In the following pages shows the standard fit (6H and 2B) for threads M, MF, UNC, UNF and GAS ➤

TOLLERANZE DI FABBRICAZIONE SUI DIAMETRI MEDI DEI MASCHI

MANUFACTURING TOLERANCES ON PITCH DIAMETER

M - ISO Passo GROSSO *ISO Metric Coarse Thread*

Ød1	P mm	Diametri medi 6H - Pitch diameter 6H	
		Min	Max
2	0,4	1,761	1,776
2,5	0,45	2,231	2,246
3	0,5	2,699	2,715
3,5	0,6	3,137	3,155
4	0,7	3,574	3,593
4,5	0,75	4,042	4,061
5	0,8	4,510	4,530
6	1	5,385	5,409
7	1	6,385	6,409
8	1,25	7,226	7,251
9	1,25	8,226	8,251
10	1,5	9,068	9,096
11	1,5	10,068	10,096
12	1,75	10,911	10,943
14	2	12,752	12,786
16	2	14,752	14,786
18	2,5	16,430	16,466
20	2,5	18,430	18,466
22	2,5	20,430	20,466
24	3	22,115	22,157
27	3	25,115	25,157
30	3,5	27,794	27,839
33	3,5	30,794	30,839
36	4	33,473	33,520
39	4	36,473	36,520
42	4,5	39,152	39,202
45	4,5	42,152	42,202
48	5	44,832	44,885
52	5	48,832	48,885
56	5,5	52,512	52,568
60	5,5	56,512	56,568
64	6	60,193	60,253
68	6	64,193	64,253

M, MF, UNC, UNF

Dimensioni in mm
Dimensions in mm

$$H = 0,866\ 03\ P$$

$$H_1 = \frac{5}{8} H = 0,541\ 27\ P$$

$$h_3 = \frac{17}{24} H = 0,613\ 43\ P$$

$$d_2 = D_2 = d - \frac{3}{4} H = d - 0,649\ 52\ P$$

$$d_3 = d - 2\ h_3 = d - 1,223\ 87\ P$$

$$r = \frac{H}{6} = 0,144\ 34\ P$$

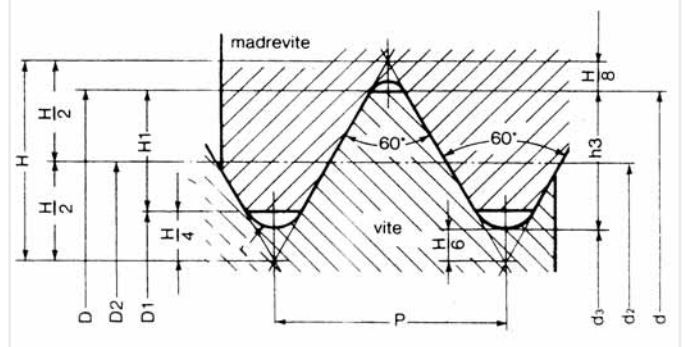

MF - ISO Passo FINE *ISO Metric Fine Thread*

Ød1	P mm	Diametri medi 6H - Pitch diameter 6H	
		Min	Max
2,5	0,35	2,293	2,307
3	0,35	2,794	2,809
3,5	0,35	3,294	3,309
4	0,5	3,699	3,715
4,5	0,5	4,199	4,215
5	0,5	4,699	4,715
5,5	0,5	5,199	5,215
6	0,75	5,545	5,566
7	0,75	6,545	6,566
8	1	7,385	7,409
9	1	8,385	8,409
10	1	9,385	9,409
10	1,25	9,226	9,251
12	1,25	11,230	11,258
12	1,5	11,071	11,101
14	1,25	13,230	13,258
12	1,5	11,071	11,101
15	1,5	14,071	14,101
16	1,5	15,071	15,101
17	1,5	16,071	16,101
18	1,5	17,071	17,101
18	2	16,752	16,786
20	1,5	19,071	19,101
20	2	18,752	18,786
22	1,5	21,071	21,101
22	2	20,752	20,786
24	1,5	23,074	23,106
24	2	22,755	22,791
25	1,5	24,074	24,106
25	2	23,755	23,791
27	1,5	26,074	26,106
27	2	25,755	25,791
28	1,5	27,074	27,106
28	2	26,755	26,791
30	1,5	29,074	29,106
30	2	28,755	28,791
30	3	28,115	28,157
32	1,5	31,074	31,106
32	2	30,755	30,791
33	1,5	32,074	32,106
33	2	31,755	31,791
33	3	31,115	31,157

Ød1	P mm	Diametri medi 6H - Pitch diameter 6H	
		Min	Max
35	1,5	34,074	34,106
36	1,5	35,074	35,106
36	2	34,755	34,791
36	3	34,115	34,157
39	1,5	38,074	38,106
39	2	37,755	37,791
39	3	37,115	37,157
40	1,5	39,074	39,106
40	2	38,755	38,791
40	3	38,115	38,157
42	1,5	41,074	41,106
42	2	40,755	40,791
42	3	40,115	40,157
42	4	39,473	39,520
45	1,5	44,074	44,106
45	2	43,755	43,791
45	3	43,115	43,157
45	4	42,473	42,520
48	1,5	47,077	47,111
48	2	46,758	46,796
48	3	46,118	46,163
48	4	45,477	45,527
50	1,5	49,077	49,111
50	2	48,758	48,796
50	3	48,118	48,163
52	1,5	51,077	51,111
52	2	50,758	50,796
52	3	50,118	50,163
55	4	52,477	52,527
55	1,5	54,077	54,111
55	2	53,758	53,796
55	3	53,118	53,163
55	4	52,477	52,527
56	1,5	55,077	55,111
56	2	54,758	54,796
56	3	54,118	54,163
56	4	53,477	53,527

TOLLERANZE DI FABBRICAZIONE SUI DIAMETRI MEDI DEI MASCHI

MANUFACTURING TOLERANCES ON PITCH DIAMETER

Filettatura **UNC** (ASME B1.1) *UNC Coarse Thread*

Ød1	P TPI	Diametri medi 2B - Pitch diameter 2B	
		Min	Max
Nr. 1	64	1,611	1,626
Nr. 2	56	1,904	1,919
Nr. 3	48	2,186	2,201
Nr. 4	40	2,447	2,462
Nr. 5	40	2,777	2,792
Nr. 6	32	3,009	3,029
Nr. 8	32	3,670	3,690
Nr. 10	24	4,158	4,178
Nr. 12	24	4,818	4,838
1/4	20	5,570	5,590
5/16	18	7,066	7,086
3/8	16	8,538	8,558
7/16	14	9,979	9,999
1/2	13	11,475	11,495
9/16	12	12,957	12,977
5/8	11	14,425	14,445
3/4	10	17,450	17,470
7/8	9	20,452	20,472
1	8	23,397	23,417
1-1/8	7	26,292	26,317
1-1/4	7	29,467	29,492
1-3/8	6	32,249	32,274
1-1/2	6	35,424	35,449
1-3/4	5	41,240	41,270
2	5	47,223	47,253
2-1/4	5	53,583	53,603
2-1/2	4	59,475	59,495
2-3/4	4	65,826	65,846
3	4	72,176	72,196

Filettatura **UNF** (ASME B1.1) *UNF Fine Thread*

Ød1	P TPI	Diametri medi 2B - Pitch diameter 2B	
		Min	Max
Nr. 0	80	1,333	1,348
Nr. 1	72	1,640	1,655
Nr. 2	64	1,941	1,956
Nr. 3	56	2,235	2,250
Nr. 4	48	2,516	2,531
Nr. 5	44	2,815	2,830
Nr. 6	40	3,107	3,122
Nr. 8	36	3,727	3,747
Nr. 10	32	4,330	4,350
Nr. 12	28	4,916	4,936
1/4	28	5,800	5,820
5/16	24	7,290	7,310
3/8	24	8,877	8,897
7/16	20	10,333	10,353
1/2	20	11,920	11,940
9/16	18	13,416	13,436
5/8	18	15,004	15,024
3/4	16	18,064	18,084
7/8	14	21,097	21,127
1	12	24,075	24,105
1-1/8	12	27,250	27,280
1-1/4	12	30,425	30,455
1-3/8	12	33,600	33,630
1-1/2	12	36,775	36,805

GAS

Dimensioni in mm
Dimensions in mm

$$P = \frac{25,4}{z}$$

$$H = 0,960 491 P$$

$$H_1 = 0,640 327 P$$

$$r = 0,137 329 P$$

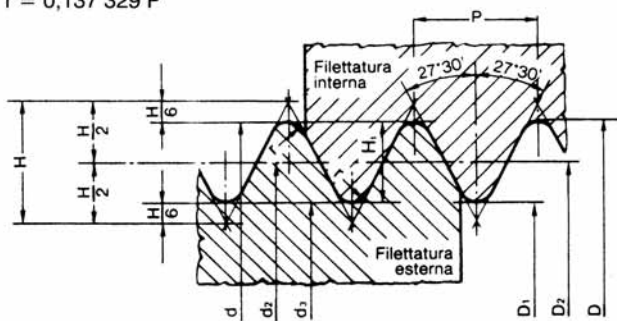

Filettatura **GAS** Cilindrica *Whitworth pipe Thread*

Ød1	P TPI	Diametri medi - Pitch diameter	
		Min	Max
1/8	28	9,189	9,209
1/4	19	12,349	12,369
3/8	19	15,849	15,869
1/2	14	19,848	19,868
5/8	14	21,798	21,818
3/4	14	25,328	25,348
7/8	14	29,088	29,108
1	11	31,831	31,851
1-1/8	11	36,481	36,501
1-1/4	11	40,491	40,511
1-3/8	11	42,901	42,921
1-1/2	11	46,391	46,411
1-3/4	11	52,351	52,371
2	11	58,211	58,231
2-1/4	11	64,321	64,341
2-3/8	11	68,011	68,031
2-1/2	11	73,791	73,811
2-3/4	11	80,151	80,171
3	11	86,501	86,521
3-1/4	11	92,601	92,621
3-1/2	11	98,951	98,971
3-3/4	11	105,301	105,321
4	11	111,651	111,671

RIVESTIMENTI E TRATTAMENTI SUPERFICIALI

COATINGS AND SURFACE TREATMENTS

Rivestimenti PVD - PVD Coating

	Codice UFS	Microdurezza HV 0,05	Coefficiente di attrito	Temperatura di massima lavorazione	Proprietà	Applicazione
	UFS Code	Micro hardness	Friction coefficient	Maximum working temperature	Properties	Applications
TiN	T	2300	0,4	600	Resistenza all'usura <i>Wear resistance</i>	Rivestimento di base per applicazioni generali e lavorazione degli acciai basso e medio legati. <i>Coating for general applications and machining low and medium alloy steels.</i>
TiN-G	TG	2300	0,2	600	Resistenza all'usura e buone proprietà di scorrimento <i>Wear resistance and good sliding properties</i>	Applicazioni generali per maschiatura a rullare ad alto rendimento, UFS TOP serie X2 ed X3. <i>General applications for high-performance former taps, UFS TOP series X2 and X3.</i>
TiCN	CT	3000	0,4	400	Resistenza all'usura <i>Wear resistance</i>	Applicazione su materiali abrasivi come la ghisa, leghe di nichel e titanio. <i>Application on abrasive materials (ex. cast iron), nickel and titanium alloys.</i>
CrN Nitruro di cromo	NC	3000	0,25	850	Resistenza all'usura, all'ossidazione e scorrimento del truciolo. <i>Oxidation and wear resistance, chip evacuation</i>	Applicazione su acciaio di medio – bassa resistenza. Particolarmente indicato per rame, ottone, bronzo e zama. <i>Application on medium - low resistance steel. Particularly suitable for copper, brass, bronze and zamak.</i>
TiAlN Tinalox	TX	3500	0,4	900	Resistenza all'usura e all'ossidazione <i>Oxidation and wear resistance</i>	Applicazione per materiali abrasivi (ghisa), a secco e per alte velocità di taglio. Lavorazioni su acciai ad alta resistenza legati e temprati. <i>Application for abrasive materials (cast iron), dry machining and for high speed cutting. Working on high-strength alloy steel and hardened.</i>
ZrN Nitruro di zirconio	TZ	1600	-	-	Scorrimento del truciolo <i>Chip evacuation</i>	Ad esaurimento scorte o su richiesta. Applicazione per alluminio e sue leghe. <i>Exhausted for standard item or on request. Application for aluminium and its alloys.</i>
VS Vaporizzazione Super Super steam tempering	VS	1600	0,15	380	Scorrimento del truciolo <i>Chip evacuation</i>	Nuovo rivestimento di ultima generazione, evoluzione della classica vaporizzazione. Trova applicazione su alluminio a basso contenuto di silicio, accia dolci e materiali teneri con tendenza ad incollare. <i>New coating, latest generation, evolution of the classic steam tempering for low % Si aluminium, low resistance steel and soft materials with a tendency to stick.</i>
NS Nitruazione super Super Nitriding	NS	2300	0,15	600	Resistenza all'usura <i>Wear resistance</i>	Rivestimento di nuova generazione sviluppato per una graduale sostituzione della classica nitruazione NQ. Applicazione tradizionale per lavorazioni su ghisa. <i>New coating developed for a gradual replacement of the classic nitriding NQ. Traditional application for machining cast iron.</i>
XP TiN-X Plus	XP	2300	0,15	600	Resistenza all'usura e scorrimento del truciolo <i>Wear resistance and chip evacuation</i>	Nuovo rivestimento per acciai di medio bassa resistenza, particolarmente consigliato per maschiatura compensata. <i>New coating for medium-low resistance steel, recommended for tapping with axial compensation.</i>
TXC Tinalox + Carbon	TXC	3500	0,15	850	Resistenza all'usura, all'ossidazione e scorrimento del truciolo <i>Oxidation and wear resistance, chip evacuation</i>	Combinazione di un rivestimento 3500 HV ed uno strato autolubrificante, consigliato per maschiatura di fori ciechi profondi. Applicazione su INOX ed Alluminio con alto contenuto di Si. <i>Combination of a coating 3500 HV and a lubricating layer, recommended for tapping blind deep holes. Application on stainless steel and aluminium with a high % of Si</i>

RIVESTIMENTI E TRATTAMENTI SUPERFICIALI

COATINGS AND SURFACE TREATMENTS

Trattamenti superficiali - Surface Treatments

	Codice UFS	Microdurezza HV 0,05	Coefficiente di attrito	Temperatura di massima lavorazione	Proprietà	Applicazione
	UFS Code	Micro hardness	Friction coefficient	Maximum working temperature	Properties	Applications
V Vaporizzazione Steam Tempering	V	400	-	-	Scorrimento del truciolo Chip evacuation	Trattamento superficiale di base indicato per la lavorazione degli acciai dolci o basso legati, acciai automatici (AVP) e alluminio puro o con basso contenuto di silicio. <i>Basic surface treatment suited for machining soft steel, low alloy steels, automatic steel (AVP), pure aluminium and aluminium low % Si</i>
NQ Nitrurazione NQ Nitriding NQ	NQ	1300	-	-	Resistenza all'usura Wear resistance	Trattamento superficiale di tipo tradizionale utilizzato per lavorazioni della ghisa e del bronzo a truciolo corto. <i>Traditional surface treatment used for machining cast iron and short chip bronze.</i>

VAPORIZZAZIONE

STEAM TEMPERING

Tanti sono i trattamenti superficiali specifici per i materiali da filettare, ma volendo semplificare al massimo, 2 sono quelli che si dividono la maggior percentuale d'impiego e, quindi, di vendita.

There are so many specific surface treatments for threaded materials, but to simplify it as much as possible, most applications use two different types.



Forno di vaporizzazione
Steam tempering plant



Forno di rivestimento
Coating plant

COMPARAZIONE DUREZZE

HARDNESS COMPARISON TABLE

HV Vickers Durezza Hardness	HRC Rockwell Durezza Hardness	HB Brinell Durezza Hardness	Resistenza - <i>Tensile Strength</i> N/mm ² Tons/sq. in.	
940	68			
900	67			
864	66			
829	65			
800	64			
773	63			
745	62			
720	61			
698	60			
675	59			
655	58		2200	142
650		618	2180	141
640		608	2145	139
639	57	607	2140	138
630		599	2105	136
620		589	2070	134
615	56	584	2050	133
610		580	2030	131
600		570	1995	129
596	55	567	1980	128
590		561	1955	126
580		551	1920	124
578	54	549	1910	124
570		542	1880	122
560	53	532	1845	119
550		523	1810	117
544	52	517	1790	116
540		513	1775	115
530		504	1740	113
527	51	501	1730	112
520		494	1700	110
514	50	488	1680	109
510		485	1665	108
500		475	1630	105
497	49	472	1620	105
490		466	1595	103
484	48	460	1570	102
480		456	1555	101
473	47	449	1530	99
470		447	1520	98
460		437	1485	96
458	46	435	1480	96
450		428	1455	94
446	45	424	1440	93
440		418	1420	92

HV Vickers Durezza Hardness	HRC Rockwell Durezza Hardness	HB Brinell Durezza Hardness	Resistenza - <i>Tensile Strength</i> N/mm ² Tons/sq. in.	
434	44	416	1400	91
423	43	402	1360	88
413	42	393	1330	86
403	41	383	1300	84
392	40	372	1260	82
382	39	363	1230	80
373	38	354	1200	78
364	37	346	1170	76
355	36	337	1140	74
350		333	1125	73
345	35	328	1110	72
340		323	1095	71
336	34	319	1080	70
330		314	1060	69
327	33	311	1050	68
320		304	1030	67
317	32	301	1020	66
310	31	295	995	64
302	30	287	970	63
300		285	965	62
295		280	950	61
293	29	278	940	61
290		276	930	60
287	28	273	920	60
285		271	915	59
280	27	266	900	58
275		261	880	57
272	26	258	870	56
270		257	865	56
268	25	255	860	56
265		252	850	55
260	24	247	835	54
255	23	242	820	53
250	22	238	800	52
245		233	785	51
243	21	231	780	50
240		228	770	50
235		223	755	49
230		219	740	48
225		214	720	47
220		209	705	46
215		204	690	45
210		199	675	44
205		195	660	43
200		190	640	41

GRUPPI MATERIALE

MATERIAL GROUPS

1 Acciaio
Steel

268 ÷ 269 ▶

Acciaio legato – Alta resistenza e Temprato
Alloyed steel – high strength steel an hardened steel

269 ÷ 270 ▶

2 Acciaio INOX
Stainless Steel

270 ÷ 271 ▶

3 Ghisa
Cast Iron

272 ▶

4 Alluminio, Magnesio
Aluminum, Magnesium

273 ÷ 274 ▶

5 Rame
Cooper

274 ÷ 275 ▶

6 Titanio
Titanium

275 ▶

7 Nichel
Nickel

275 ÷ 276 ▶

8 Materie plastiche
Synthetic materials

276 ▶

9 Materiali Speciali
Special Materials

277 ▶

10 Grafite
Graphite

277 ▶

1		Acciaio - Steel		
1.1		Acciaio dolce magnetico Rm < 400 N/mm², < 120 HB		
		<i>Magnetic soft steel</i>		
	W-Nr.	DIN - Germany	UNI - Italy	
	1.1013	RFe100	-	
	1.1014	Rfe80	-	
	1.1015	Rfe60	-	
1.2		Acciaio da costruzione, da cementazione, automatico Rm < 700 N/mm², < 200 HB		
		<i>Structural steel, case carburizing steel, free cutting steel</i>		
	W-Nr.	DIN - Germany	UNI - Italy	
Acciaio da costruzione <i>Structural steel</i>	1.0037	St37-2	Fe360B	
	1.0044	St44-2	Fe430B	
	1.0050	St50-2	Fe490	
	1.0060	St60-2	Fe590	
	1.0070	St70-2	Fe690	
	1.0570	St52-3	Fe510B, C, D	
Acciaio da cementazione <i>Case carburizing steel</i>	1.0301	C10	C10	
	1.0401	C15	C15	
	1.0402	C22	C20, C21	
	1.0406	C25	C25	
	1.7131	16MnCr5	16MnCr5	
	1.7147	20MnCr5	20MnCr5	
	1.5919	15CrNi6	16CrNi4	
	1.6523	21NiCrMo2	20NiCrMo2	
Acciaio automatico (AVP) <i>Free cutting steel</i>	1.0711	9S20	CF10S20	
	1.0715	9SMn28	CF9SMn28	
	1.0718	9SMnPb28	CF9SMnPb28	
	1.0726	35S20	CF35SMn10	
	1.0736	9SMn36	CF9SMn36	
	1.0737	9SMnPb36	CF9SMnPb36	
1.3		Acciaio al carbonio Rm < 850 N/mm², < 250 HB		
		<i>Plain carbon steel</i>		
	W-Nr.	DIN - Germany	UNI - Italy	
Da bonifica <i>Heat-treatable steel</i>	1.0528	C30	-	
	1.0501	C35	C35	
	1.0511	C40	C40	
	1.0503	C45	C45	
	1.0540	C50	-	
	1.0535	C55	C55	
	1.0601	C60	C60	
	1.1178	Ck30	-	
	1.1181	Ck35	C35	
	1.1191	Ck45	C46	

Continua Acciaio al carbonio / Continue Plain carbon steel ►

	W-Nr.	DIN - Germany	UNI - Italy
Per molle <i>Spring steel</i>	1.1231	Ck67	C70
	1.1248	Ck75	C75
	1.1269	Ck85	C85
	1.1274	Ck101	C100
Da tempra superficiale <i>Surface hardening</i>	1.1183	Cf35	C36, C38
	1.1193	Cf45	C43
	1.1213	Cf53	C53
1.4	Acciaio legato - bonificato, fusioni d'acciaio Rm < 850 N/mm², < 250 HB <i>Alloyed steel - tempered steel, steel castings</i>		
1.5	Acciaio legato - bonificato Rm 850 ÷ 1200 N/mm², 250 ÷ 350 HB <i>Alloyed steel - tempered steel</i>		
1.6	Acciaio legato - alta resistenza Rm 1200 ÷ 1400 N/mm², 38 ÷ 45 HRC <i>Alloyed steel - high strength steel</i>		
1.7	Acciaio legato - alta resistenza Rm 1400 ÷ 1600 N/mm², 45 ÷ 49 HRC <i>Alloyed steel - high strength steel</i>		
1.8	Acciaio legato - temprato 49 ÷ 62 HRC <i>Hardened steel</i>		
	W-Nr.	DIN - Germany	UNI - Italy
Da bonifica <i>Heat-treatable steel</i>	1.7035	41Cr4	41Cr4
	1.8159	50CrV4, 51CrV4	51CrV4
	1.7218	25CrMo4	25CrMo4
	1.7220	34CrMo4	35CrMo4
	1.7225	42CrMo4	42CrMo4
	1.7228	50CrMo4	-
	1.7242	16CrMo4	18CrMo4
	1.6580	30CrNiMo8	30NiCrMo8
	1.6582	34CrNiMo6	35NiCrMo6 (KW)
	1.6511	36CrNiMo4	38NiCrMo4 (KB)
	1.6773	36NiCrMo16	34NiCrMo16
	1.6565	40NiCrMo6	-
Da nitrurazione <i>Nitriding steel</i>	1.8515	31CrMo12	31CrMo12
	1.8519	31CrMoV9	-
	1.8507	34CrAlMo7	34CrAlMo7
	1.8509	41CrAlMo7	41CrAlMo7
Da cuscinetti <i>Ball bearing steel</i>	1.3505	100Cr6	100Cr6
	1.3537	100CrMo7	100CrMo7
Per molle <i>Spring steel</i>	1.5025	51Si7	48Si7
	1.5026	56Si7	55Si7
	1.5027	60Si7	-
	1.7108	60SiCr7	60SiCr8
	1.8159	50CrV4	50CrV4
	1.7176	55Cr3	55Cr3
	1.7701	51CrMoV4	-
Fusioni d'acciaio (ghisa acciaiata) <i>Steel castings</i>	1.0446	GS-45	-
	1.0552	GS-52	-
	1.5919	GS-15CrNi6	-
	1.7218	GS-25CrMo4	-
	1.7220	GS-34CrMo4	-
	1.7379	GS-18CrMo9-10	-

Continua Acciaio legato / Continue Alloyed steel ►

	W-Nr.	DIN - Germany	UNI - Italy
Per tempra superficiale <i>Surface hardening</i>	1.7005	45Cr2	-
	1.7006	46Cr2	46Cr2
	1.7043	38Cr4	-
	1.7034	37Cr4	36CrMn4
	1.7223	41CrMo4	41CrMo4
Per lavorazioni a caldo <i>Hot work tool steel</i>	1.2767	45NiCrMo16	42NiCrMo 15 7
	1.2713	55NiCrMoV6	-
	1.2714	55NiCrMoV7	55NiCrMoV7KU
	1.2311	40CrMnMo7	35CrMo8KU
	1.2365	X32CrMoV3-3	30CrMoV12-27KU
	1.2343	X38CrMoV5-1	X37CrMoV5-1KU
	1.2344	X40CrMoV5-1	X40CrMoV5-1-1KU
	1.2567	X30WCrV5-3	X30WCrV5-3KU
Per lavorazioni a freddo <i>Cold work tool steel</i>	1.2581	X30WCrV9-3	X30WCrV9-3KU
	1.2080	X210Cr12	X205Cr12KU
	1.2083	X42Cr13	-
	1.2363	X100CrMoV5-1	X100CrMoV5-1KU
	1.2379	X155CrVMo12-1	X155CrVMo12-1KU
	1.2510	100MnCrW4	95MnWCr5KU
	1.2550	60WCrV7	55WCrV8KU
	1.2842	90MnCrV8	90MnVCr8KU
Acciaio rapido HSS, HSS-E <i>High speed steel</i>	1.3202	S 12-1-4-5	(T15)
	1.3207	S 10-4-3-10	HS 10-4-3-10 (T42)
	1.3243	S 6-5-2-5	HS 6-5-2-5 (M35)
	1.3247	S 2-10-1-8	HS 2-9-1-8 (M42)
	1.3343	S 6-5-2	HS 6-5-2 (M2)
	1.3344	S 6-5-3	(M3/2)
	1.3348	S 2-9-2	HS 2-9-2 (M7)
Acciaio rapido sinterizzato HSS-PM <i>Sintered high speed steel</i>	-	HS 6-5-3-8	(ASP2030, ASP30)
	-	HS 10-2-5-8	(ASP2052, ASP52)
	-	HS 6-7-6-10	(ASP2060, ASP60)
1.7 Acciaio speciale Rm<1600 N/mm ² <i>Special steel Rm<1600 N/mm²</i>			HARDOX 400
			HARDOX 450
1.8 Acciaio speciale 49 – 62 HRC <i>Special steel 49 - 62 HRC</i>			HARDOX 500
			HARDOX 600
2	Acciaio INOX - Stainless Steel		
2.1	Acciaio INOX automatico Rm < 850 N/mm², < 250 HB		
	<i>Free machining stainless steel</i>		
	W-Nr.	DIN - Germany	UNI - Italy
1.4104	X14CrMoS17	X10CrS17 (AISI 430F)	
1.4305	X8CrNiS18-9	X10CrNiS18-9 (AISI 303)	

Continua Acciaio legato / Continue Alloyed steel ►

2.2 Austenitico Rm < 850 N/mm², < 250 HB			
<i>Austenitic stainless steel</i>			
	W-Nr.	DIN - Germany	UNI - Italy
	1.4301	X5CrNi18-10	X5CrNi18-10 (AISI 304)
	1.4306	X2CrNi19-11	X2CrNi18-11 (AISI 304L)
	1.4401	X5CrNiMo18-10	X5CrNiMo17-12 (AISI 316)
	1.4404	X2CrNiMo17-13-2	X2CrNiMo17-12 (AISI 316L)
	1.4406	X2CrNiMoN17-12-2	X2CrNiMoN17-12 (AISI 316LN)
	1.4435	X2CrNiMo18-14-3	X2CrNiMo17-13
	1.4438	X2CrNiMo18-16-4	X2CrNiMo18-15 (AISI 317L)
	1.4541	X6CrNiTi18-10	X6CrNiTi18-11 (AISI 321)
	1.4550	X6CrNiNb18-10	X8CrNiNb18-11 (AISI 347)
	1.4828	X15CrNiSi20-12	X16CrNi23-14
	1.4841	X15CrNiSi25-20	X16CrNiSi25-20 (AISI 314)
	1.4845	X12CrNi25-21	X6CrNi25-20 (AISI 310S)
2.3 Ferritico, Ferritico + Austenitico, Martensitico Rm < 1100 N/mm², < 320 HB			
<i>Ferritic, ferritic + austenitic, martensitic</i>			
	W-Nr.	DIN - Germany	UNI - Italy
Ferritico <i>Ferritic</i>	1.4002	X6CrAl13	X6CrAl13 (AISI 405)
	1.4003	X2Cr11	X2CrNi12
	1.4016	X6Cr17	X8Cr17 (AISI 430)
	1.4510	X6CrTi17	X6CrTi17 (AISI 430Ti)
	1.4509	X2CrTiNb18	X2CrTiNb18
	1.4512	X5CrTi12	X6CrTi12 (AISI 409)
Ferritico + austenitico (Bifasico) <i>Ferritic + austenitic (Duplex)</i>	1.4462	X2CrNiMoN22-5-3	X2CrNiMoN22-5-3
	1.4501	X2CrNiMoCuWN25-7-4	X2CrNiMoCuWN25-7-4
Martensitico <i>Martensitic</i>	1.4006	X10Cr13	X12Cr13 (AISI 410)
	1.4005	X12CrS13	X12CrS13 (AISI 416)
	1.4021	X20Cr13	X20Cr13 (AISI 420)
	1.4028	X30Cr13	X30Cr13
	1.4057	X17CrNi16-2	X16CrNi16 (AISI 431)
	1.4125	X105CrMo17	(AISI 440C)
2.4 Leghe Cr-Ni resistenti alle alte temperature Rm 1100 ÷ 1400 N/mm², 330 ÷ 410 HB			
<i>Cr-Ni alloys high temperatures resistant</i>			
	W-Nr.	DIN - Germany	UNI - Italy
Indurente per precipitazione <i>Precipitation hardening</i>	1.4542	X5CrNiCuNb16-4	(AISI 630, 17-4 PH)
	1.4545	X4CrNiCu16-6	(15-5 PH)
	1.4568	X7CrNiAl17-7	(17-7 PH)
	1.4922	X20CrMoV11-1	-
	1.4939	X12CrNiMo12	-
	1.4944	-	(AISI 660)
	1.4980	X6NiCrTiMoVB25-15-2	

3	Ghisa - Cast Iron		
3.1	Ghisa grigia lamellare Rm < 600 N/mm², < 180 HB		
	<i>Lamellar grey cast iron</i>		
	W-Nr.	DIN - Germany	UNI - Italy
	0.6010	GG-10	G 10
	0.6015	GG-15	G 15
	0.6020	GG-20	G 20
3.2	Ghisa grigia lamellare Rm 600 ÷ 1000 N/mm², 180 ÷ 300 HB		
	<i>Lamellar grey cast iron</i>		
	W-Nr.	DIN - Germany	UNI - Italy
	0.6025	GG-25	G 25
	0.6030	GG-30	G 30
	0.6035	GG-35	G 35
	0.6040	GG-40	G 40
3.3	Ghisa sferoidale Rm < 1000 N/mm², < 300 HB		
	<i>Nodular cast iron</i>		
	W-Nr.	DIN - Germany	UNI - Italy
	0.7033	GGG-35.3	-
	0.7040	GGG-40	GS400-12
	0.7043	GGG-40.3	GSO 42/17
	0.7050	GGG-50	GS500-7
	0.7060	GGG-60	GS600-3
	0.7070	GGG-70	GS700-2
	0.7080	GGG-80	GS800-2
	0.7670	GGG-Ni22	-
	0.7683	GGG-Ni35	-
	0.7660	GGG-NiCr20-2	-
	0.7677	GGG-NiCr30-1	-
0.7685	GGG-NiCr35-3	-	
3.4	Ghisa malleabile Rm < 700 N/mm², < 210 HB		
	<i>Malleable cast iron</i>		
	W-Nr.	DIN - Germany	UNI - Italy
	0.8035	GTW-35-04	-
	0.8045	GTW-45-07	-
	0.8145	GTS-45-06	-
	0.8165	GTS-65-02	-
	0.8170	GTS-70-02	-
3.5	Ghisa vermicolare a grafite compatta Rm 700 ÷ 1000 N/mm², 200 ÷ 300 HB		
	<i>Compacted cast iron with vermicular graphite</i>		
	W-Nr.	DIN - Germany	Denom. comm. / Trade name
			(CGI)
		(GGV)	
		(GJV)	

4 Alluminio, Magnesio – Aluminium, Magnesium			
Alluminio / Magnesio non legato Rm < 350 N/mm², < 100 HB			
4.1	<i>Aluminium / Magnesium unalloyed</i>		
	W-Nr.	DIN - Germany	UNI - Italy
	3.0205	Al99	3567 (9001/1)
	3.0255	Al99.5	4507 (9001/2)
	3.0285	Al99.8	4509 (9001/4)
	3.0305	Al99.9	-
	3.3208	Al99.9MgSi	-
	3.3308	Al99.9Mg0.5	-
	3.3318	Al99.9Mg1	-
Leghe di Al, Si < 0,5% - truciolo lungo Rm < 500 N/mm², < 150 HB			
4.2	<i>Al alloys, Si < 0,5% - long chipping</i>		
	W-Nr.	DIN - Germany	UNI - Italy
	3.0505	AlMn0.5Mg0.5	(AISI 3105)
	3.0915	AlFeSi	(AISI 8011A)
	3.3315	AlMg1	5764 (5005, Peraluman100)
	3.3525	AlMg2Mn0.3	(AISI 5251)
	3.3527	AlMg2Mn0.8	(AISI 5049)
	3.3545	AlMg4Mn	(AISI 5086)
	3.3555	AlMg5	(AISI 5056A)
	3.0615	AlMgSiPb	(AISI 6012)
	3.1255	AlCuSiMn	3581 (AISI2014)
	3.1325	AlCuMg1	3579 (AISI 2017A, Avional 100)
	3.1355	AlCuMg2	3583 (AISI 2024, Avional 150)
	3.3547	AlMg4.5Mn	7790 (AISI 5083, Peraluman 460)
	3.3206	AlMgSi0.5	3569 (AISI 6060, Anticorodal 050)
	3.2315	AlMgSi1	3571 (AISI 6082, Anticorodal 110)
	3.4365	AlZnMgCu1.5	3735 (AISI 7075, Ergal 55)
	3.1371	G-AlCu4TiMg	-
	3.3241	G-AlMg3Si	-
	3.3261	G-AlMg5Si	-
	3.3541	G-AlMg3	-
	Leghe di Al, Si < 10% - truciolo medio Rm < 500 N/mm², < 150 HB		
4.3	<i>Al alloys, Si < 10% - medium chipping</i>		
	W-Nr.	DIN - Germany	UNI - Italy
	3.2134	G-AISI5Cu1Mg	3600
	3.2161	G-AISI8Cu3	5075
	3.2162.05	GD-AISI8Cu3	-
	3.2371	G-AISI7Mg	7257
	3.2373	G-AISI9Mg	3051
Leghe Al, Si > 10% - truciolo corto Rm < 600 N/mm², < 180HB			
4.4	<i>Al alloys, Si > 10% - short chipping</i>		
	W-Nr.	DIN - Germany	UNI - Italy
	3.2381	G-AISI10Mg	3049
	3.2383	G-AISI10Mg(Cu)	-
	3.2581	G-AISI12	5079
	3.2583	G-AISI12(Cu)	3048

Continua leghe di Magnesio / Continue Magnesium alloys ►

4.5	Leghe standard di magnesio Rm 120 ÷ 300 N/mm²			
	<i>Magnesium standard alloys</i>			
	W-Nr.	DIN - Germany	Denom. comm. / Trade name	
	3.5200	MgMn2	(MAGNUMINIUM 133)	
	3.5312	MgAl3Zn	(AZ31)	
	3.5632	MgAl6Zu3	(AZ63)	
4.6	Leghe di magnesio ad alta resistenza Rm 240 ÷ 400 N/mm², 70 ÷ 120 HB			
	<i>High strength magnesium alloys</i>			
	3.5161	MgZn6Zr	(ZK60)	
	3.5612	MgAl6Zn1	(AZ61)	
5	RAME - Cooper			
5.1	Rame puro, rame elettrolitico - truciolo lungo Rm < 350 N/mm², < 100 HB			
	<i>Cooper unalloyed - long chipping</i>			
	W-Nr.	DIN - Germany	Denom. comm. / Trade name	
	2.0040	OF-Cu	-	
	2.0060	E-Cu57	-	
	2.0065	E-Cu58	-	
	2.0070	Se-Cu	-	
5.2	Leghe di rame, α ottone - truciolo lungo Rm < 700 N/mm², < 200 HB			
	<i>Cooper alloys, soft brass - long chipping</i>			
	W-Nr.	DIN - Germany	Denom. comm. / Trade name	
	2.0240		CuZn15, Ms85 -	
	Ottone / Brass	2.0250	CuZn20, Ms80	-
		2.0265	CuZn30, Ms70	-
		2.0280	CuZn33, Ms67	-
		2.0321	CuZn37, Ms63	-
		2.0335	CuZn36, Ms64	-
	Bronzo / Bronze	2.1016	CuSn4	-
2.1020		CuSn6	-	
2.1030		CuSn8	-	
2.1080		CuSn6Zn6	-	
5.3	Leghe di rame, β ottone, bronzo - truciolo corto Rm < 700 N/mm², < 200 HB			
	<i>Cooper alloys, hard brass, bronze - short chipping</i>			
	W-Nr.	DIN - Germany	Denom. comm. / Trade name	
	Ottone / Brass	2.0360	CuZn40 (Ms60)	-
		2.0380	CuZn39Pb2 (Ms58)	-
		2.0410	CuZn44Pb2 (Ms56)	-
		2.0510	CuZn37Al1	-
		2.0550	CuZn40Al2	-
		2.0561	CuZn40Al1	-
		2.0580	CuZn40Mn1Pb	-
		2.2140	G-ZnAl4	(ZAMAK)
	Bronzo / Bronze	2.1086	G-CuSn10Zn	-
		2.1093	G-CuSn6ZnNi	-
2.1096		G-CuSn5ZnPb	-	

Continua Bronzo / Continue Bronze ►

5.4	Bronzo ad alta resistenza Rm < 1500 N/mm², < 440 HB		
	<i>High strength bronze</i>		
	W-Nr.	DIN - Germany	Denom. comm. / Trade name
	2.0932	CuAl8Fe3	(Ampco12)
	2.0936	CuAl10Fe3Mn2	(Ampco16, Ampco 15)
	2.0940	CuAl10Fe	-
	2.0966	CuAl10Ni5Fe4	(Ampco)
	2.0978	CuAl11Ni6Fe5	-
-	CuAl11Fe4	(Ampco 20)	
2.0882	CuNi30MnFe	-	
6	Titanio - Titanium		
	Titanio non legato Rm < 700 N/mm², < 200 HB		
6.1	<i>Titanium unalloyed</i>		
	W-Nr.	DIN - Germany	Altro / Other
	3.7024	Ti99.8	T35, Grade 1
	3.7034	Ti99.7	T40, Grade 2
	3.7055	Ti99.6	T50, Grade 3
3.7064	Ti99.5	T60, Grade 4	
6.2	Leghe di titanio Rm < 900 N/mm², < 270 HB		
	<i>Titanium alloys</i>		
6.3	Leghe di titanio Rm < 1400 N/mm², < 410 HB		
	<i>Titanium alloys</i>		
	W-Nr.	DIN - Germany	Altro / Other
	3.7124	TiCu2	-
	3.7154	TiAl6Zr5	-
	3.7164, 3.7165	TiAl6V4	Grade 5
3.7174	TiAl6V6Sn2	-	
3.7184	TiAl4Mo4Sn2	-	
7	Nichel - Nickel		
	Nichel non legato Rm < 500 N/mm², < 150 HB		
7.1	<i>Nickel unalloyed</i>		
	W-Nr.	DIN - Germany	Denom. comm. / Trade name
	1.3911	Rni24	-
	1.3926	Rni12	-
	1.3927	Rni8	-
	2.4061	Ni99,6	Nickel 205
	2.4066	Ni99,2	Nickel 200
	2.4068	LC-Ni99	Nickel 201
7.2	Leghe di Nichel Rm < 900 N/mm², < 270 HB		
	<i>Nickel alloys</i>		
7.3	Leghe di Nichel Rm < 1600 N/mm², < 470 HB		
	<i>Nickel alloys</i>		
	W-Nr.	DIN - Germany	Denom. comm. / Trade name
	1.3911	X2Ni36	Invar
2.4360	NiCu30Fe	Monel 400	
2.4375	NiCu30Al	Monel K500	

Continua leghe Nichel / Continue Nickel alloys ➤

7.2 – 7.3	W-Nr.	DIN - Germany	Denom. comm. / Trade name
	2.4602	NiCr17Mo17FeW	Hastelloy C
	2.4630	Ni-Cr20Ti	Nimonic 75
	2.4631	NiCr20TiAl	Nimonic 80A
	2.4634	NiCo20Cr15MoAlTi	Nimonic 105
	2.4636	NiCo15Cr15MoAlTi	Udimet 700
	2.4654	NiCr20Co14MoTi	Waspaloy
	2.4662	NiCr13Mo6Ti3	Nimonic 901
	2.4665	NiCr22Fe18Mo	Hastelloy X
	2.4668	NiCr19Fe19NbMo	Inconel 718
	2.4670	G-NiCr13Al6MoNb	Nimocast 713
	2.4674	NiCo15Cr10MoAlTi	Nimocast PK24
	2.4816	NiCr15Fe	Inconel 600
	2.4856	NiCr22Mo9Nb	Inconel 625
8	Materie plastiche - <i>Synthetic materials</i>		
8.1	Materiali termoplastici - truciolo extralungo Rm < 80 N/mm² <i>Thermoplastics – extra long chipping</i>		
	W-Nr.	DIN - Germany	Denom. comm. / Trade name
	-	-	ABS
	PE	Polyethylene	Hostalen
	PP	Polypropylene	Hostalen PP
	PVC	Polyvinyl chloride	Hostalit, Vestolit, Vinoflex
	PS	Polystyrene	Polystyrol
	PMMA	Polymethyle acryle	Plexiglas
	PTFE	Polytetrafluorethylene	Teflon
	PA	Polyamide	Nylon, Ultramid
	PC	Polycarbonate	Makralon
	PI	Thermoplastic polyamide	Kinel
8.2	Materiali termoindurenti - truciolo corto Rm < 110 N/mm² <i>Thermosetting plastics – short chipping</i>		
	W-Nr.	DIN - Germany	Denom. comm. / Trade name
	PF	Phenol formaldehyde	Pertinax
	MF	Melamine formaldehyde	Albanit, Resopal
	UF	Urea formaldehyde	Bakelite
8.3	Materie plastiche con fibre di rinforzo Rm 800 ÷ 1500 N/mm², 240 ÷ 440 HB <i>Reinforced plastic materials</i>		
	W-Nr.	DIN - Germany	Denom. comm. / Trade name
	AFK	Aramid	Kevlar
	BFK	Boron	Boro
	CFK	Carbon fibre	Resine + Fibra di carbonio
	GFK	Glass fibre	Resine + fibre di vetro
	SFK	Synthetic fibre	Resine + fibre sintetiche

9	Materiali Speciali - <i>Special Materials</i>		
9.1	Materiali metallo - ceramici (Cermets) Rm < 1700 N/mm², < 51 HRC		
	<i>TIC - Hard materials</i>		
	W-Nr.	DIN - Germany	Denom. comm. / Trade name
			Ferritan
			Ferro Titanit
			Ferrotic
9.2	Leghe a base Cobalto Rm < 1200 N/mm², < 350 HB		
	<i>Alloys on cobalt base</i>		
	W-Nr.	DIN - Germany	Denom. comm. / Trade name
			AiResist
			Biodur
			Celsit
			Haynes Alloy
			Stellite
9.3	Leghe di tungsteno Rm < 1800 N/mm², < 52 HRC		
	<i>Tungsten alloys</i>		
	W-Nr.	DIN - Germany	Denom. comm. / Trade name
			Anviloy
			Denal
			Densimet
			Mallory
10	Grafite - <i>Graphite</i>		
10.1	Grafite Rm < 100 N/mm²		
	<i>Graphite</i>		
	W-Nr.	DIN - Germany	Denom. comm. / Trade name
			Graphit R8340
			Technograph 15
			Technograph 30
			R8510
			R8650
			Union Poco EDM1
			Union Poco EDM3